

NEW

Viper
Rock Reamer™

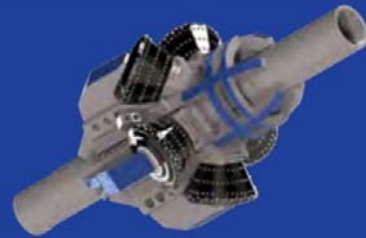

149 Hours



Vipers Going To Work



72" MT Viper



Viper Cutters

Viper  **Rock Reamer™**

Horizontal Technology, Inc.



Table of Content



Page 01	About Horizontal Technology, Inc.
Page 02	Features & Benefits of the Viper & Jumbo Viper
Page 03	Reasons the Viper & Jumbo Viper are HDD's Best
Page 04	Mini & Midsize Rig Tooling - Size Chart & Suggested RPM
Page 05	Mini & Midsize Rig Tooling - Dimensions & Weights
Page 06	Large Rig Tooling - Size Chart & Suggested RPM
Page 07	Large Rig Tooling - Dimensions & Weights
Page 08	Jumbo Viper - Size Chart & Suggested RPM
Page 09	Jumbo Viper - Dimensions & Weights
Page 10	Experience is Critical
Page 11 - 13	General Guideline For Viper Operations (RPM, Weight, GPM)
Page 14 - 17	Formation Characteristics
Page 18 - 19	How Many Passes & What Sizes
Page 20	Formation Removal Chart
Page 21	Formation Transition; Getting Into the Rock
Page 22 - 23	The Use of Centralizers
Page 24	Problems With Centralizers
Page 25	Field Adjustable Stabilizers; Ringed Centralizers
Page 26	How to Change Cutters
Page 27	Projecting Cutter Life
Page 28	Mini & Midsize Rig Viper - Estimated Cutter Life
Page 29	Large Rig Viper - Estimated Cutter Life
Page 30 - 31	Jumbo Viper - Estimated Cutter Life
Page 32 - 33	Vipers vs. Split Bits
Page 34	PDC - Fixed Blade Hole Openers
Page 35 - 37	Viper Case Studies
Page 37	Make-up Torque Chart

HDD's

- ✓ **Strongest**
 - ✓ **Longest Lasting**
 - ✓ **Most Versatile**
- Hole Opener**

**Head to Head . . .
undefeated!!**

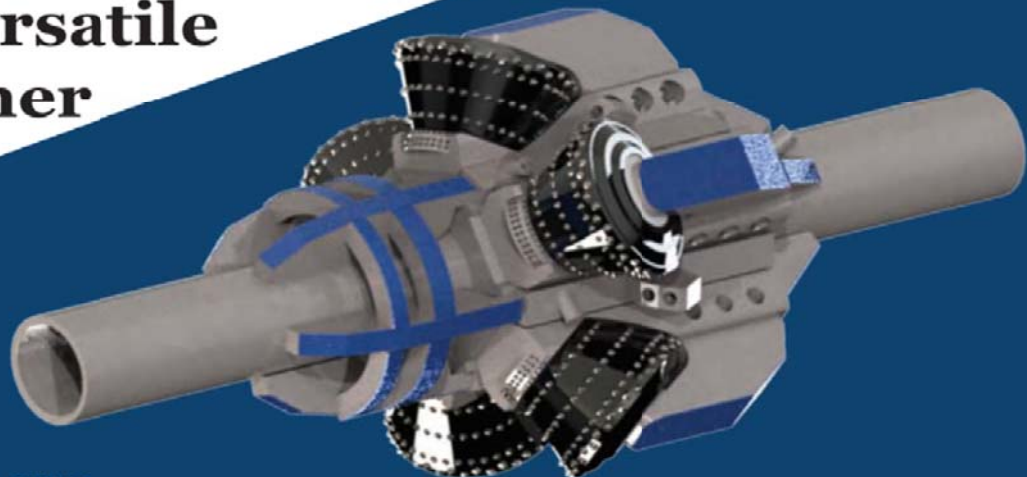

(888) 556 - 5511

www.horizontaltech.com



From the north slope of Alaska to the jungles of South America, Horizontal Technology, Inc. has participated in some of River Crossing's most challenging projects. Servicing HDD contractors around the world, your project is, and will always be, our most important priority. We combine the most advanced technology with the best trained Navigators in the industry. Our products include the industry's most accurate MGS/Gyro steering system, powerful short-radius motors and the acclaimed Viper Hole Enlarger; all specifically designed and developed for the rugged drilling conditions common to HDD. It's not just a man or a piece of equipment, our entire company is working for your project.

Horizontal Technology, Inc. is a leader committed to improving the safety and professionalism of the HDD Industry. We will continue raising our standards and that of the industry through innovative developments, education and training. From the company's founding, we have valued quality over quantity by basing our success on the successes of our clients. We are committed to maintaining our position as the HDD Industry's premier guidance service and down-hole tooling provider. Our mission is to be a positive asset to our clients and to the successful completion of each and every project without compromising safety or integrity.

Horizontal Technology leads the way in pipeline integrity management. Our precise records and guidance documentation set the standard, adding value to our services and protection to our clients. The Horizontal Technology Team is ready to take your call and respond immediately, 24 hours a day, 7 days a week.

John English

Founder & President

Horizontal Technology, Inc.

HDD's Best Hole Opener Just Got Better!!!

STRONGER * LONGEST LASTING * LOWER TORQUE

8 3/4" to 72"

Better Production, Lower Costs

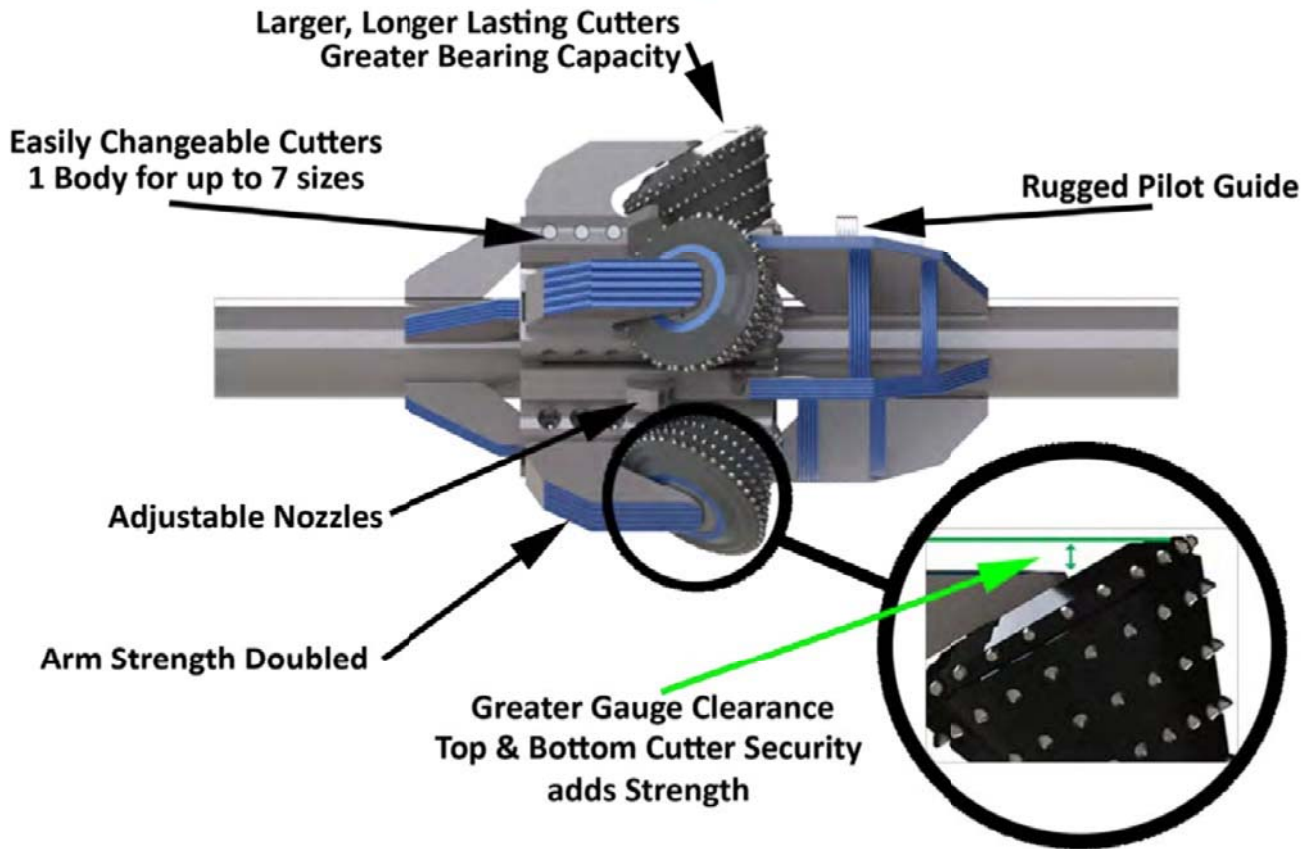

FEATURES

- Proprietary Bearing Design
- Larger Cutter
- Maximum Shirrtail Protection
- Engineered Insert Configuration
- Customized / Reverse Nozzles
- Match the Cutter to the Formation
- Stronger Design
- Versatile Design
- Easily Changeable Cutters



\$ BENEFITS \$

- Increased Weight Capability With Less Torque
- Longer Cutter Life
- Improved Cutter Security
- Maximum Cutter Efficiency
- Improved Circulation & Cleaning
- Improved Penetration Rates
- Minimizes Risk, Longer Life
- Lowers Cost
- No Down-Time



A Smart Choice!



3 Reasons the Viper & Jumbo Viper are HDD's best hole opening tools.

Reason #1. Pure Strength

Unlike other designs, where the cutter is only secured on one side, the Viper can sustain far more weight and much longer wear, with far less risk. Split bit designed tools can spit a cone at any time costing thousands and perhaps the entire hole. The dead pull weight capability of the Viper design exceeds that of any split bit hole opener. The Viper's strong, field replaceable arms secure the cutters at ID and OD, reducing risks, while extending down-hole operating hours significantly.

Reason #2. Cost \$\$

You only pay for the cutters you use. No need to purchase and then wait on the building of tools you hope turn out to be the correct style. With down time being HDD's most costly problem, the ability to replace cutters, change cutters to match formation or even change the size of the hole opener at no cost and with no waiting can be the difference between a profit or a loss. The Viper allows HDD contractors to take cutters from one size body and use them on the next size, saving thousands of dollars.

Reason #3. Cutter Design & Performance

The Viper hole opener combines maximum cutter size, bearing capability, improved seals, adjustable jet nozzles and strategically designed inserts/teeth combined with properly engineered angles to create the longest lasting, best performing hole opener to date. The Viper's proprietary cutter design lasts longer, allows more weight, improves penetration and reduces torque. Matching forward and reverse jet nozzles to rig GPM cleans the cutting shoulder and protects the Viper hole opener body, reducing wear. Strategic angles protect cutter arms from bottom-side hole cuttings, extending arm and cutter life while improving tool efficiency.



Viper RockReamer

Mini & Midsize Rig Tooling



V4

4 1/2" Minimum Pilot

V6

6 1/2" Minimum Pilot

V6-18

18" Minimum Pilot

BODY	NO. OF CUTTERS	MINIMUM PILOT HOLE	CONNECTION (Box x Box)	OPENING RANGE				
				aaa	bbb	ccc		
V4	3	4 1/2"	2 7/8 IF	8 3/4"	10"	12"		

BODY	NO. OF CUTTERS	MINIMUM PILOT HOLE	CONNECTION (Box x Box)	OPENING RANGE				
				aa	bb	cc	dd	ee
V6	3	6 1/2"	3 1/2 IF, 4 1/2 IF	12"	14"	16"	18"	20"
V6-18	5	18"	3 1/2 IF, 4 1/2 IF	22"	24"	26"	28"	30"
V6-24	5	24"	3 1/2 IF, 4 1/2 IF	28"	30"	32"	34"	36"

*Cutters are field replaceable and interchangeable between bodies.
Available in soft, medium and hard formation.*

Tool	Cutter	Opening Size	Suggested Max. RPM
V4	aaa	8 3/4"	54
	bbb	10"	50
	ccc	12"	47

Suggested weight: Start about 2 times the formations PSI.
Adjust as needed.

Tool	Cutter	Opening Size	Suggested Max. RPM
V6	aa	12"	54
	bb	14"	51
	cc	16"	50
	dd	18"	47
	ee	20"	46

Suggested weight: Start about 2 times the formations PSI.
Adjust as needed.

Tool	Cutter	Opening Size	Suggested Max. RPM
V6-18	aa	22"	29
	bb	24"	30
	cc	26"	30
	dd	28"	30
	ee	30"	31

Suggested weight: Start about 3 times the formations PSI.
Adjust as needed.

Tool	Cutter	Opening Size	Suggested Max. RPM
V6-24	aa	28"	23
	bb	30"	24
	cc	32"	25
	dd	34"	25
	ee	36"	25

Suggested weight: Start about 3 times the formations PSI.
Adjust as needed.



Dimensions & Weights

Viper RockReamer

Mini & Midsize Rig Tooling

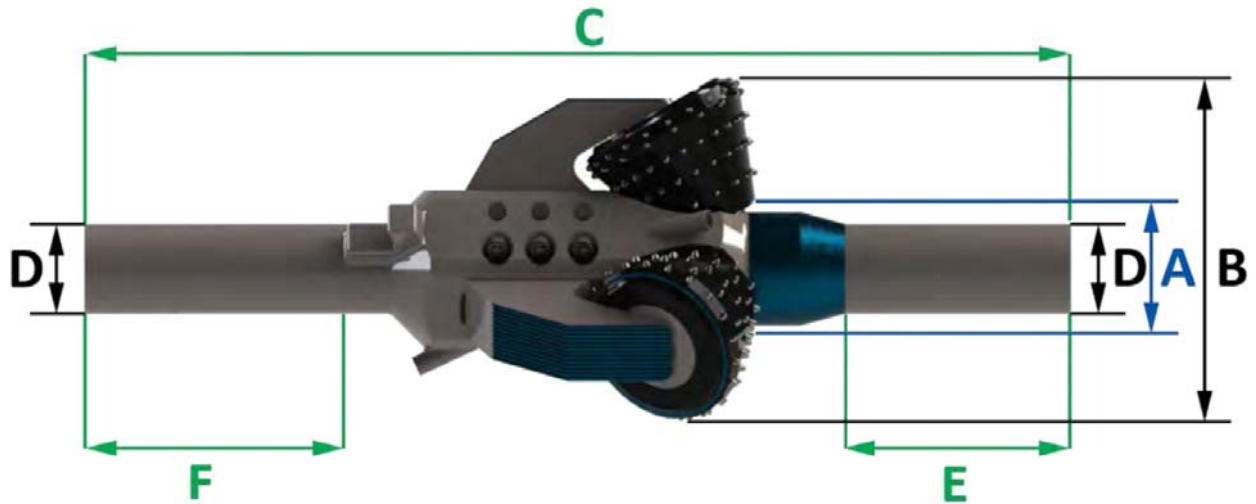

	Standard Connection (Box x Box)	Minimum Pilot Hole	Opening Ranges	Length	Fishing Neck OD	Approximate Forward Neck Length	Approximate Back Neck Length
		A	B	C	D	E	F
V4	2 ½ IF	4 ½"	8 ¾", 10", 12"	43"	4"	10"	13"
V6	3 ½ IF	6 ½"	12", 14", 16", 18", 20"	53"	4 ¾"	10"	14"
V6-18	3 ½ IF	18"	22", 24", 26", 28", 30"	62"	4 ¾"	12"	17"
V6-24	3 ½ IF	24"	28", 30", 32", 34", 36"	62"	4 ¾"	12"	17"

	Weight (Body Only)	Cutter	Size	Weight dressed with Milled Tooth	Weight dressed with TCI Cutter
V4	148	aaa	8 ¾"	190	193
		bbb	10"	202	208
		ccc	12"	223	232
V6	338	aa	12"	461	473
		bb	14"	491	512
		cc	16"	524	554
		dd	18"	575	617
		ee	20"	617	677
V6-18	1,250	aa	22"	1,455	1,475
		bb	24"	1,505	1,540
		cc	26"	1,560	1,610
		dd	28"	1,645	1,715
		ee	30"	1,715	1,815
V6-24	1,550	aa	28"	1,755	1,775
		bb	30"	1,805	1,840
		cc	32"	1,860	1,910
		dd	34"	1,945	2,015
		ee	36"	2,015	2,115

V4 Series	Weight MT Cutter (each) (lbs.)	Weight TCI Cutter (each) (lbs.)	Weight Arm (each) (lbs.)
aaa	6	7	8
bbb	9	11	9
ccc	14	17	11

V6 Series	Weight MT Cutter (each) (lbs.)	Weight TCI Cutter (each) (lbs.)	Weight Arm (each) (lbs.)
aa	15	19	26
bb	23	30	28
cc	33	43	29
dd	45	59	34
ee	59	79	34



Viper

RockReamer

Large Rig Tooling



V8

8 1/2" Minimum Pilot

V10

10 5/8" Minimum Pilot

V8-24

24" Minimum Pilot

BODY	NO. OF CUTTERS	MINIMUM PILOT HOLE	CONNECTION (Box x Box)	OPENING RANGE							
				B	C	D	E	F	G	H	
V8	3	8 1/2"	4 1/2 IF, 5 1/2 FH	18"	20"	22"	24"	26"	28"	30"	
V10	4	10 5/8"	7 5/8 REG	20"	22"	24"	26"	28"	30"	32"	
V8-24	5	24"	7 5/8 REG	32"	34"	36"	38"	40"	42"	44"	

*Cutters are field replaceable and interchangeable between bodies.
Available in soft, medium and hard formation.*

Tool	Cutter	Opening Size	Suggested Max. RPM
V8	B	18"	51
	C	20"	50
	D	22"	48
	E	24"	47
	F	26"	47
	G	28"	46
	H	30"	46

Suggested weight: Start about 2 times the formations PSI.
Adjust as needed.

Tool	Cutter	Opening Size	Suggested Max. RPM
V10	B	20"	46
	C	22"	45
	D	24"	44
	E	26"	44
	F	28"	43
	G	30"	43
	H	32"	43

Suggested weight: Start about 2 1/2 times the formations PSI.
Adjust as needed.

Tool	Cutter	Opening Size	Suggested Max. RPM
V8-24	B	32"	28
	C	34"	29
	D	36"	29
	E	38"	30
	F	40"	30
	G	42"	30
	H	44"	31

Suggested weight: Start about 3 times the formations PSI.
Adjust as needed.



Dimensions & Weights

Viper RockReamer

Large Rig Tooling

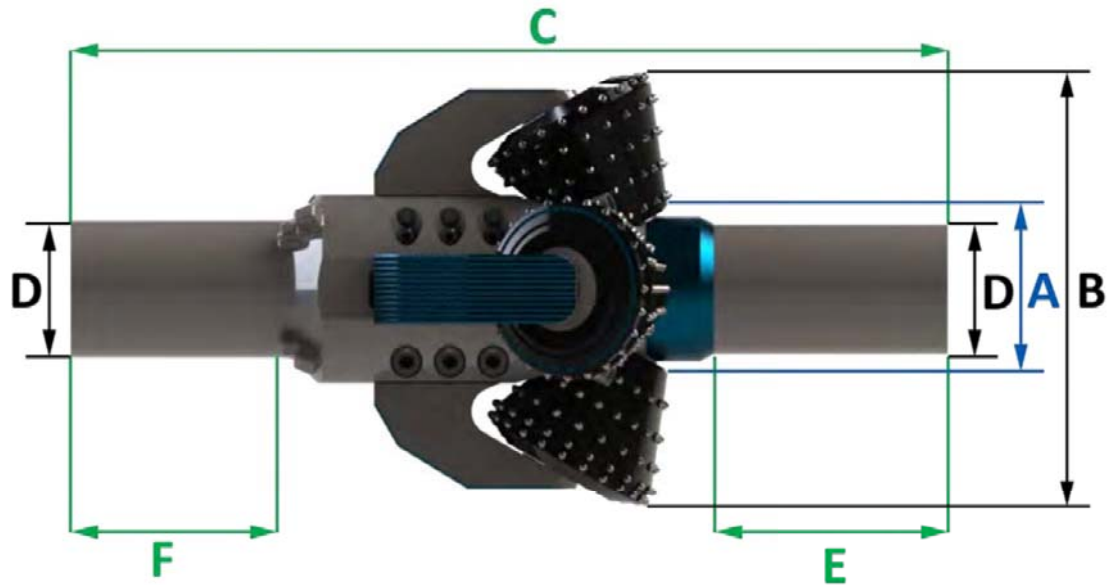

	Standard Connection (Box x Box)	Minimum Pilot Hole	Opening Ranges	Length	Fishing Neck OD	Approximate Forward Neck Length	Approximate Back Neck Length
		A	B	C	D	E	F
V8	4 ½ IF	8 ½"	18", 20", 22", 24", 26", 28", 30"	62"	6 ½"	14"	14"
V10	7 ¾ Reg	10 ¾"	20", 22", 24", 26", 28", 30", 32"	62"	9 ½"	14"	14"
V8-24	7 ¾ Reg	24"	32", 34", 36", 38", 40", 42", 44"	79"	9 ½"	17"	17"

	Weight (Body Only)	Cutter	Size	Weight dressed with Milled Tooth	Weight dressed with TCI Cutter
V8	729	B	18"	1,089	1,125
		C	20"	1,149	1,203
		D	22"	1,242	1,308
		E	24"	1,326	1,413
		F	26"	1,407	1,521
		G	28"	1,503	1,641
V10	1,350	H	30"	1,629	1,794
		B	20"	1,830	1,878
		C	22"	1,910	1,982
		D	24"	2,034	2,122
		E	26"	2,146	2,262
		F	28"	2,254	2,406
V8-24	3,095	G	30"	2,382	2,566
		H	32"	2,550	2,770
		B	32"	3,695	3,755
		C	34"	3,795	3,885
		D	36"	3,950	4,060
		E	38"	4,090	4,235
		F	40"	4,225	4,415
		G	42"	4,385	4,615
		H	44"	4,595	4,870

Large Viper Series	Weight MT Cutter (each) (lbs.)	Weight TCI Cutter (each) (lbs.)	Weight Arm (each) (lbs.)
B	53	65	67
C	70	88	70
D	90	112	81
E	112	141	87
F	138	176	88
G	167	213	91
H	200	255	100



Jumbo Viper

RockReamer

Large Rig Tooling



Jumbo Viper

BODY	NO. OF CUTTERS	MINIMUM PILOT HOLE	CONNECTION (Box x Box)	OPENING RANGE			
				JC	JD	JE	JF
JV20	5	20"	7 5/8 REG	30"	32"	34"	36"
JV26	5	26"	7 5/8 REG	36"	38"	40"	42"
JV32	5	32"	7 5/8 REG	42"	44"	46"	48"
JV38	5	38"	7 5/8 REG	48"	50"	52"	54"
JV44	5	44"	7 5/8 REG	54"	56"	58"	60"
JV50	5	50"	7 5/8 REG	60"	62"	64"	66"
JV56	5	56"	7 5/8 REG	66"	68"	70"	72"

*Cutters are field replaceable and interchangeable between bodies.
Available in soft, medium and hard formation.*

Tool	Cutter	Opening Size	Suggested Max. RPM
JV20	JC	30"	43
	JD	32"	42
	JE	34"	42
	JF	36"	43

Suggested weight: Start about 3 times the formations PSI.
Adjust as needed.

Tool	Cutter	Opening Size	Suggested Max. RPM
JV26	JC	36"	36
	JD	38"	36
	JE	40"	36
	JF	42"	36

Suggested weight: Start about 3 times the formations PSI.
Adjust as needed.

Tool	Cutter	Opening Size	Suggested Max. RPM
JV32	JC	42"	30
	JD	44"	31
	JE	46"	31
	JF	48"	32

Suggested weight: Start about 3 times the formations PSI.
Adjust as needed.

Tool	Cutter	Opening Size	Suggested Max. RPM
JV38	JC	48"	27
	JD	50"	27
	JE	52"	27
	JF	54"	28

Suggested weight: Start about 3 times the formations PSI.
Adjust as needed.

Tool	Cutter	Opening Size	Suggested Max. RPM
JV44	JC	54"	24
	JD	56"	24
	JE	58"	25
	JF	60"	25

Suggested weight: Start about 3 times the formations PSI.
Adjust as needed.

Tool	Cutter	Opening Size	Suggested Max. RPM
JV50	JC	60"	21
	JD	62"	22
	JE	64"	22
	JF	66"	23

Suggested weight: Start about 3 times the formations PSI.
Adjust as needed.

Tool	Cutter	Opening Size	Suggested Max. RPM
JV56	JC	66"	19
	JD	68"	20
	JE	70"	20
	JF	72"	21

Suggested weight: Start about 3 times the formations PSI.
Adjust as needed.



Dimensions & Weights

Jumbo Viper RockReamer

Large Rig Tooling

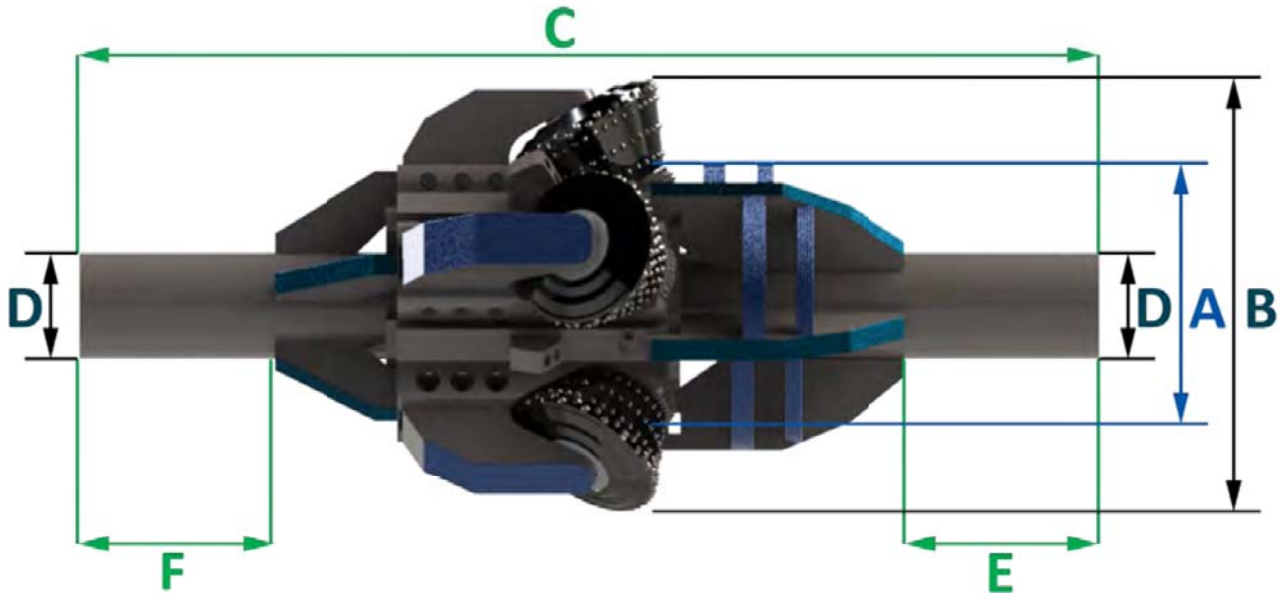

	Standard Connection (Box x Box)	Minimum Pilot Hole	Opening Ranges		Length	Fishing Neck OD	Approximate Forward Neck Length	Approximate Back Neck Length
			A	B				
JV20	7 ½ Reg	20"	30", 32", 34", 36"	81"	9 ½"	17"	17"	
JV26	7 ½ Reg	26"	36", 38", 40", 42"	96"	9 ½"	17"	17"	
JV32	7 ½ Reg	32"	42", 44", 46", 48"	96"	9 ½"	17"	17"	
JV38	7 ½ Reg	38"	48", 50", 52", 54"	96"	9 ½"	17"	17"	
JV44	7 ½ Reg	44"	54", 56", 58", 60"	96"	9 ½"	17"	17"	
JV50	7 ½ Reg	50"	60", 62", 64", 66"	96"	9 ½"	17"	17"	
JV56	7 ½ Reg	56"	66", 68", 70", 72"	96"	9 ½"	17"	17"	

	Weight (Body Only)	Cutter	Size	Weight dressed with Milled Tooth	Weight dressed with TCI Cutter
JV20	2,617	JC	30"	3,687	3,827
		JD	32"	3,892	4,087
		JE	34"	4,127	4,357
		JF	36"	4,297	4,592
JV26	3,640	JC	36"	4,710	4,850
		JD	38"	4,915	5,110
		JE	40"	5,150	5,380
		JF	42"	5,320	5,615
JV32	4,480	JC	42"	5,550	5,690
		JD	44"	5,755	5,950
		JE	46"	5,990	6,220
		JF	48"	6,160	6,455
JV38	5,563	JC	48"	6,633	6,773
		JD	50"	6,838	7,033
		JE	52"	7,073	7,303
		JF	54"	7,243	7,538
JV44	6,567	JC	54"	7,637	7,777
		JD	56"	7,842	8,037
		JE	58"	8,077	8,307
		JF	60"	8,247	8,542

	Weight (Body Only)	Cutter	Size	Weight dressed with Milled Tooth	Weight dressed with TCI Cutter
JV50	7,513	JC	60"	8,583	8,723
		JD	62"	8,788	8,983
		JE	64"	9,023	9,253
		JF	66"	9,193	9,488
JV56	8,270	JC	66"	9,340	9,480
		JD	68"	9,545	9,740
		JE	70"	9,780	10,010
		JF	72"	9,950	10,245

Jumbo Viper Series	Weight MT Cutter (each) (lbs.)	Weight TCI Cutter (each) (lbs.)	Weight Arm (each) (lbs.)
JC	122	150	92
JD	151	190	104
JE	186	232	116
JF	223	282	113



Experience is Critical



Inevitably, fundamentals are learned through experience.

Warning: Enlarging the diameter of a hole in hard formations will often be the highest single cost of completing an HDD installation. Even minor changes in formation can have a significant effect on the cost of your project. It is poor business to subsidize someone's product line with your money, equipment and time. The risk and costs of unexpected or changing conditions should not be the responsibility of the HDD contractor. Be sure your contract covers the costs of opening a hole and protects you against unforeseen variances in the formation and conditions encountered.

Warning: Because you buy a hole opener doesn't mean it will open the hole. Even the best tools need good operators. HDD requires experienced knowledgeable people to operate the equipment in the proper manner to match the circumstances and formations. Horizontal directional drilling (HDD) will tear up, break and destroy items placed down-hole. Drill pipe, cross over subs and down-hole tools will fail. Eventually everything used in the drill string will wear to a point in which it is deemed unusable. Nothing breaks at a good time. Following proper HDD methods and procedures can minimize these incidents. There are factors that can be controlled and some that cannot; regardless, things will break.

ex · pe · ri · ence (*noun*) \ik-'spir-ē-ən(t)s\

- 1: the process of doing and seeing things and of having things happen to you
- 2: skill or knowledge that you get by doing something
- 3: the length of time that you have spent doing something (such as a particular job)

Compared to vertical oil & gas drilling, conditions encountered by HDD hole-openers are very different and extreme. HDD hole openers are consumable tools that begin to wear from the moment they are rotated into the hole. Pulling a hole opener hours too early is far better than a minute too late. Knowing how to drill and how to utilize a hole opener is as important as choosing the right tool. Finesse is far more important than horse power when it comes to successfully opening a horizontal hole; however, the trend of more powerful rigs and larger drill pipe combined with an influx of inexperienced drillers will undoubtedly result in an increase in broken and damaged down-hole tools. That's why the strength and design of the Viper RockReamer is so important.

This is not a "how to" manual. The goal of extending the life of a HDD hole opener will often conflict with the goal of maximizing penetration rates. This handbook points out the design features and benefits of the Viper RockReamer in comparison to other HDD hole opening products. It also offers ideas and examples of how the hole opening process can play out using various methods and procedures. Successful contractors consider possible formation changes and down time when selecting the best products for their project. Building MT split-bits only to find out the formation requires TCI is costly in both time and money. Horizontal Technology, Inc. and the Viper hole opener have eliminated that risk. HDD is a very risky business. The time and money invested in a completed pilot hole should not be jeopardized by selecting the cheapest product to enlarge the hole. The Viper can assist in lowering costs and minimizing risks.



General Guideline for Viper Hole Opener Operations

Have a good plan. **Keep good records, including penetration rates, weight, RPM and GPM.** Comparing pilot hole data with hole opening data will provide critical drilling information. Good records will increase the chances of success on every project. After investing significant time and dollars in a pilot hole, taking risks during the hole opening process isn't advised. Utilize proven HDD methods and practices. Avoid short cuts.

For drillers, the three most discussed variables are RPM, weight applied, and mud/GPM. The fourth variable is the most important; the design & style of the hole opener selected. Some tools are better designed than others. Tool choice will have a direct affect on penetration rates and cutter's life; even more important, on cutter security. The wrong tool will increase the chances of fishing for a lost cone.

There is always a balance between penetration rates and the life of a HDD hole opener. Keep your weight and RPM as low as possible while maintaining acceptable penetration rates. Tool design, cutter type, tool diameter, size of rig, drilling fluids, pumps, cleaning systems, formations encountered, drill pipe size, pilot hole size, direction of ream, driller experience, drill path design, angles, curves, elevations, contracts and even over-reaching inspectors will have an ever changing influence on the best weight, RPM and GPM. All factors should relate to the selection of the proper tool.

RPM

For penetration, softer formations generally react better to an increase in RPM; the harder the formation, the slower the RPM. Softer formations allow less weight and greater RPM; harder formations require more weight and slower RPM.

A cutter's rotation, on its own axis, is affected by the cutter size, hole size and the rotary of the drill pipe. The operator should be aware of these factors. Using a 36" hole, for example, a cutter with an 8" diameter (common for many split bits) will rotate 4.5 times for every RPM of the drill pipe. Therefore, at 50 rpm, the individual cutter is rotating at 225 RPM. Bit thirds have small bearings, not designed to rotate at these RPM's.

A cutter with a diameter of 14.75", like the Jumbo Viper, has much larger bearings and it will rotate about 122 RPM, or about half the RPM of the split bit hole opener under the same conditions. The obvious benefit is longer cutter life, plus the ability to safely increase the RPM and improve penetration rates.

Weight

Weight and RPM are tied together. Each affects the other. The harder the formation, the more weight needed to create rock failure. Because friction is a result of speed and weight, increased weight should coincide with slower RPM.

The greater the size of the cutting shoulder, the more weight required. More cutters generally require more weight but the size of the cutters is also a factor. This is a matter of weight distribution. Five large cutters may have equal square inches of contact as seven smaller cutters.



Pull weight and weight on the hole opener isn't necessarily the same. The weight and friction of the drill pipe must be considered. A crooked hole will hamper drilling mechanics, reducing actual weight at the cutting shoulder. Centralizers can hang up or create a ledge, masking actual weight at the cutting shoulder of the hole opener. As drill pipe is pulled against the top of the hole, rotary torque and weight on tool are effected. Actual weight on cutters is difficult to determine.

As formation and grain angles vary, the mechanics of the operation can change continuously throughout the length of the drill. Reaming mechanics usually improve as the hole opener turns up and nears the rig.

Needed weight will go up with the hardness of the formation. The best weight will vary with changing condition. The required weight will increase with the size of the cutting shoulder as well as the PSI hardness of the rock.

Weight will have a direct effect on the penetration rate. It will also have an effect on the life of the cutter.

Start with a weight, approximately 2 to 3 times the PSI hardness of the formation, and adjust as needed. When you find the weight and RPM that provides the best penetration you can usually slack off about 10%. This "sweet spot" will likely change throughout the bore.

The dead pull weight limit of the Viper RockReamers is at least equal to that of the drill pipe connections. However, rotary and leverage calculations can create forces far in excess of those limits so never pull harder than is required for smooth rotational operation of the Viper.



Mud/GPM

It is always advisable to have an experienced HDD mud engineer on site.

The drilling fluids remove the cuttings and cool the hole opener cutters. Never operate a Viper hole opener in a dry hole. It is very important to have as clean a hole as possible. Generally speaking, in most HDD hole opening operations, you will not pump too much. Cobble and gravel create problems. Nothing destroys cutters or hole opener bodies quicker than loose cuttings. It is difficult to circulate cuttings once settled on the bottom of the hole. Proper jetting and placement of weeper subs can assist in cleaning the hole. HTI blade type centralizers assist in recirculating settled cuttings from the bottom of the hole into the flow of drilling fluid, increasing the percentage of formation removed from the hole.

In alluvial formations, where fly cutters are commonly used, penetration rates and GPM are closely related. As the reamer advances and cuttings are created, you need to remove them from the hole. If you ream too fast, you may outrun the removal of the cuttings. A Rule-Of-Thumb is to displace the mud a minimum of 4-5 times during the time it takes to drill each joint.

A quick, ball park way to calculate maximum acceptable fly cutter penetration rates

Square the diameter of the hole (in inches) and multiply by .0408. For 30' rigs, multiply that by 30. For 5 times displacement, multiply by 5. Divide that by the GPM you will pump and that is a ball park, maximum, minutes per joint penetration rate.

Example: For 36" diameter hole, 30' drill pipe, 5 times displacement at 500 GPM.
 $(36" \times 36" \times .0408 = 52.87 \times 30' = 1,586.30 \times 5 = 7931.52 / 500 \text{ GPM} = 15.86 \text{ minutes per joint})$

Roller cone hole openers are used in harder formations where penetration rates are usually slower. Even so, it is unlikely HDD contractors will be able to pump the needed GPM to completely clean a large diameter hole. Most HDD rigs will have limited GPM and cleaning capabilities. Pay attention to your returns. Settled cuttings are hard to move. Deviations in hole direction and elevation will create areas where cuttings accumulate, sometimes bridging off circulation. Swab the hole when needed. The point is that you will not be able to pump too much when enlarging a horizontal rock hole. Be sure your mud is at a good viscosity with maximum yield and, in most cases, pump all the GPM you can.



Good Hole Opening Practices Begin with a Straight Pilot hole.

Bad pilot holes can create issues during the hole opening process. Minimize deviations. Curves, even designed curves, can create unwanted hole opening issues. Rotating drill pipe will try and key-seat through a curve. In some situations, this can affect the final location of the line. In other situations, key-seated pipe can restrict the forward movement of centralizers or hole openers, making a hole opening pass impossible.

Key-Seat

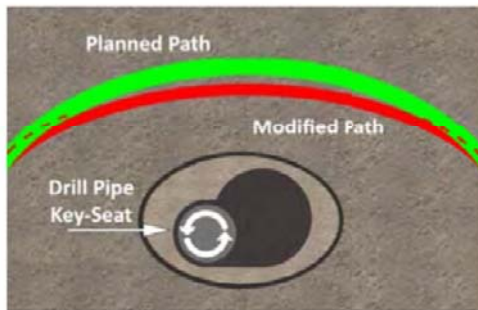

Key-seating drill pipe gradually increases torque. The newly created key-seat hole is under gauge restricting the forward movement of the hole opening BHA. Once created, a key-seat problem is difficult to verify and even more difficult to resolve. One solution is strategically placed centralizers keeping the drill pipe from sliding into the key seat.

Formation Characteristics Will Have An Effect On Tooling Costs?

When bidding, most estimators/contractors focus on PSI, and they should. The PSI of the formation to be drilled and opened will have a direct effect on the time and cost of any drill; the harder the formation, the slower the penetration rate. What look like minimal PSI increases can double the drilling costs. If a joint takes 1 hour to open in 15,000 PSI it may take 2 hours to open in 20,000 PSI. The greater the weight needed to advance the tool, the shorter the lifespan of the cutter set. While PSI's are important, other characteristics of the formation may also have significant effects on tooling costs.

Cuttings size and rock density are important factors in flushing the hole clean. Dense, heavy rock is difficult to lift and remove. Any loose material such as boulders, cobble, gravel and accumulated cuttings will cause damage and shorten the life of down-hole tools very quickly.

This will quickly and dramatically increase the cost of opening a hole. The larger the hole the greater the problem. In cases of extreme cobble or gravel content, some holes will be impossible to keep open and may need to be grouted. If the hole can be maintained, the larger

the diameter the more likely loose impediments will accumulate on the bottom of the hole. Simply rotating the drill string, in loose cuttings, can create dramatic wear on anything down-hole including the drill pipe. As the OD wears evenly, sometimes this damage isn't obvious until the pipe is inspected. Depending on the length and duration of the project, the entire drill string may need to be scrapped after used in a dirty hole. Loose cuttings in the pilot hole can damage the front of the hole opener as if it were being machined in a lathe. Tools can easily be damaged beyond repair due to OD wear.



Cuttings accumulate at the bottom of the hole. If in the pilot hole, they will damage the portion of the tool rotating in the pilot hole.

The outer gauge of the cutters will repeatedly be rolled through and over the loose cuttings. Damage to these parts (*) of a hole opener indicate excessive loose materials. Nothing else can contact the cutter shell. A scalloped like wear pattern around the back/top of a cutter's circumference, just between and behind the gauge inserts, is an indicator of a dirty hole. Because the arms are designed to be under gauge, wear to the OD of the arms is a good indication of a loose material problem.

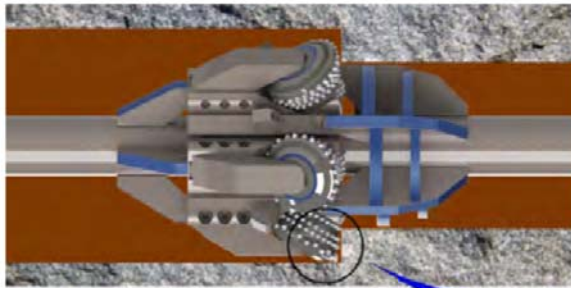
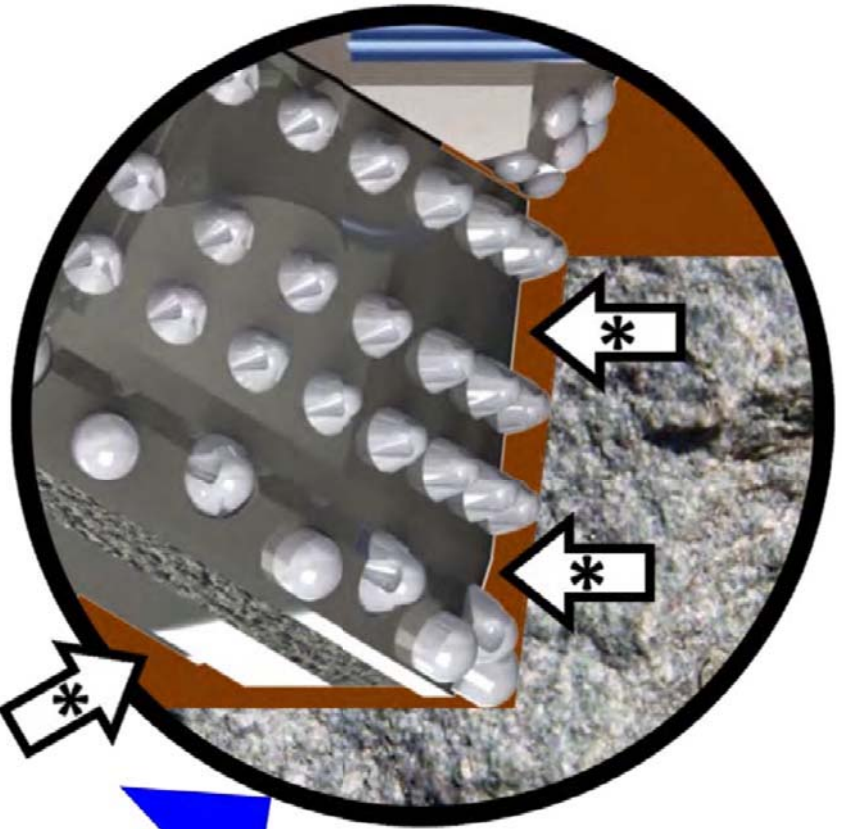

Cutter life is reduced dramatically as solid content, in the hole, is increased. In ideal conditions, the cutter inserts create rock failure as they rotate making contact with the formation. The shell of the cutter does not contact the rock. Loose material forced around the inserts damage the shell. As the cutters rotate across the bottom of the hole they will rotate over the top of the cuttings, pinching the tool between the cuttings and the top of the hole. Extreme pressure will be forcing the gravel and cuttings up and all around the cutter inserts, damaging the cutter shell itself. As damage to the cutter shells accrue, support for the TCI inserts wear, allowing individual inserts to turn, lean or fall out. This, in turn, damages the neighboring inserts. Depending on the abrasiveness of the materials this happens very quickly. A cutter that would last 120 hours in even the hardest of formations could easily be reduced to 30 hours in gravel or loose cuttings.



Loose Cuttings Need To Be Removed.



Damaged From Loose Cuttings.



Large Cuttings Are Very Difficult To Remove.

HDD rarely allows 100% removal of the cuttings from the hole. The larger the cuttings, the more difficult they will be to flush from the hole. Elevation changes will factor into the flow of the drilling fluids and movement of the cuttings. Cutters will experience greater damage when heading down as gravity drops solids at the cutting shoulder. As the hole opener moves upward, cuttings usually fall away from the cutting shoulder. However, if the elevation dictates the fluid moves in the same direction as the hole opener, cuttings will still accumulate at the cutting shoulder.

Cobble and gravel are a factor in many HDD projects and loose cuttings are the consequence of creating a hole. The density and abrasiveness of the formation being drilled combined with the geometry of the hole, will have significant effect on the ability to flush cuttings from the hole. Taking the time to swab each joint will lessen cuttings at the hole opening shoulder. A good mud program can improve the efficiency of flushing cuttings from the hole and therefore performance of a hole opener.

Loose impediments will shorten hole opener cutter life significantly. Every project, to one extent or another will deal with the problems caused by loose cuttings. The existence of cobble and/or gravel plus other characteristics of the formation should be considered in the planning and estimating process.

Cutter and Insert Styles IADC

HDD Hole opener cutter styles are often described using the first number from the IADC code; a three number code based on oilfield nomenclature. This is misleading as the IADC 3 digit number refers to bits only and would have an altered significance even with split bits hole openers. The **first number is the most applicable** when using the IADC code for hole opener cutter selection.



IADC is The **International Association of Drilling Contractors**, an organization representing the international oil and gas drilling industry since the 1940's.

The **first digit**, 1-8, represents the hardness of rock for which the drill bit is designed.

Number 1, 2 and 3: Indicates a steel tooth bit (MT), engineered for soft formations.

Number 4, 5, 6, 7, and 8: Indicates tungsten carbide inserts (TCI). Within this category 4 is designated for the softer formations, with 8 representing the hardest formations.

The **second digit** uses numbers 1-4 and represents further bit features such as gauge, journal angles and drag design with 1 being the softest and 4 the hardest. This is mostly irrelevant as it applies to hole openers.

The **third digit** uses numbers from 1-7, representing the bearing type of the bit, from open bearing to sealed. All Viper RockReamers have sealed bearings - not the case with split bits hole openers.

That said, HTI's hole opener cutter sets combine multiple first digit IADC comparisons on any one cutter. Even some of our MT cutters have TCI inserts at gauge. Each cutter set has a variety of insert patterns usually combining multiple insert styles. Generally the best HDD hole openers are a 5 to 6 IADC comparison. Because HDD contractors operate horizontally, in drilling conditions that place severe stress on the gauge of the cutters, a 5 style IADC cutter will have the equivalent gauge IADC of 7 or 8 on the same cutter. Bit thirds angles are skewed so that the tips of the bits overlay the center of the bit and are relatively small compared to real hole opener cutters. The large size of HTI's hole opener cutters allow increased customization to improve cutter performance.



The question of matching the hole opener cutter styles to formation is often overthought. Ideas evolve as quickly as projects move from one area to another. Generally matching the cutter selection one IADC step up from the best performing drill bit will work well. It is hard for HDD rigs to apply appropriate weight during a pilot hole, so an aggressive bit will provide better penetration and steering. The same idea will apply if push reaming or where you can't get the needed weight. However, when pull reaming, a cutter designed for the rock being encountered, will improve performance and durability.

For HDD, MT cutters are used in formations up to about 6,000 PSI. Even so, the specific formation and equipment being used will dictate how the MT cutters perform and how long they will last. In hard clays and also where the cuttings react like clay, the formation may ball up on the cutters. When this happens the cutters are no more than slick bowling balls and penetration will cease. Mud additives and proper jet placement can improve the situation.

As the cutting edge of the teeth on MT cutters dull, maintaining the same penetration will require more and more weight, which in turn further dulls the teeth. Other considerations will come into play. The length of the drill may suggest TCI as a better selection, even though MT will work, simply to be able to finish the drill without a cutter trip.

TCI cutters come in a variety of styles. **Chisel** inserts have been a popular HDD selection for softer formations but they will chip and break easily. Once a break occurs the adjacent inserts will break easier setting up a domino effect which dramatically reduces the life of the cutter set. There are aggressive **conical** inserts that have the same IADC designation as the chisel and do not break as easily. The best option may be a more aggressive insert that maintains the strength of a harder formation conical. Introducing HDD's newest **Rives Triple V TCI Insert**:

NEW, IMPROVED TCI INSERT



The new Viper RockReamer features proprietary TCI & MT cutter designs. The new **Rivers Triple V TCI Insert** combines the aggressive contact area of a chisel with the strength of a conical. The **Rivers Triple V TCI** allows greater per insert weight without losing strength. The design improves penetration rates while minimizing insert damage; longer life, lower costs.



The new **Rivers Triple V TCI Insert** pattern has the aggression of a 5 type IADC code and the strength of a 6 combined with a gauge protection of a 7.

How Many Passes & What Sizes?

The Viper allows contractors a lot of flexibility. In fact, you could open from pilot hole to 48" in as few as two passes (Pilot to 32" to 48"). While this isn't the best strategy for most situations, the Viper was designed to fit your specific needs. The flexibility of the Viper RockReamer gives the contractor many cost saving options. With on-the-shelf tools from 8 3/4" to 72", the Viper can be quickly adjusted to match any plan or formation.

There are many factors that determine the best plan for reaching the needed final hole. In most instances, finesse trumps horsepower. The best plan is always a balance of time and money. Formation, rig size, drill string size, pump capabilities, bore length, contract, and tool capability/availability are just a few of the considerations.

Softer formations allow larger increases and fewer passes. The harder the formation the greater the need for incremental steps.

For example, the Viper allows the contractor to open from pilot hole direct to 32" if the need is there. In some situations, in some formations, with some rigs, this is a viable plan. In other situations it will likely take two passes and in harder rock, more. The point is to determine the best plan for your project.

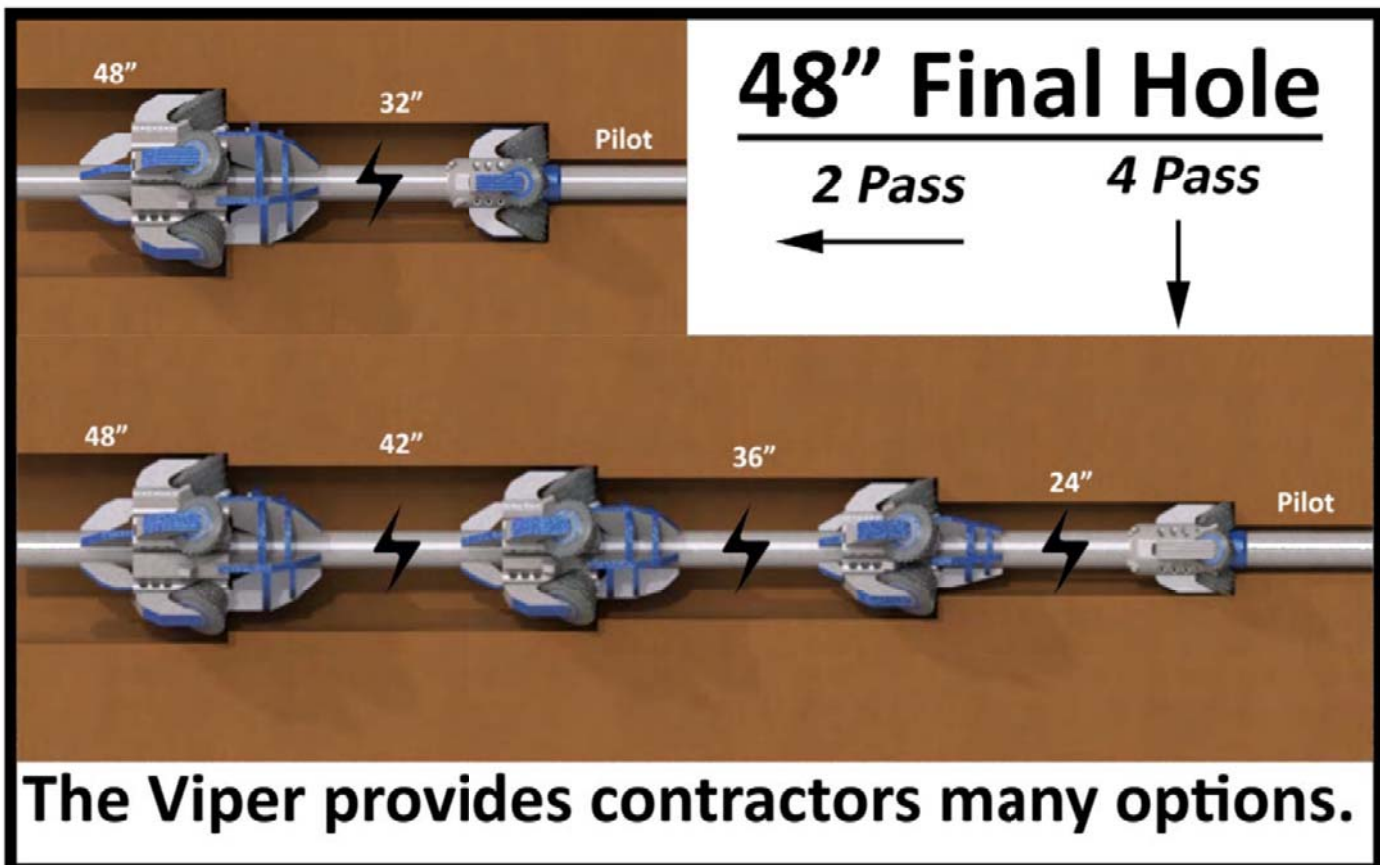

With the Viper style hole opener, contractors can **open up to 7 size holes using the same Viper body**. This saves inventory and prevents down-time. Or, as in the following example, you can use the exact same set of cutters to open multiple size passes. This alternative saves the contractors the costs of two hole openers. For the costs of cutters used on a 36" pass, you get the 30" and 20" included.

Same Cutter Set, Three Successive Passes

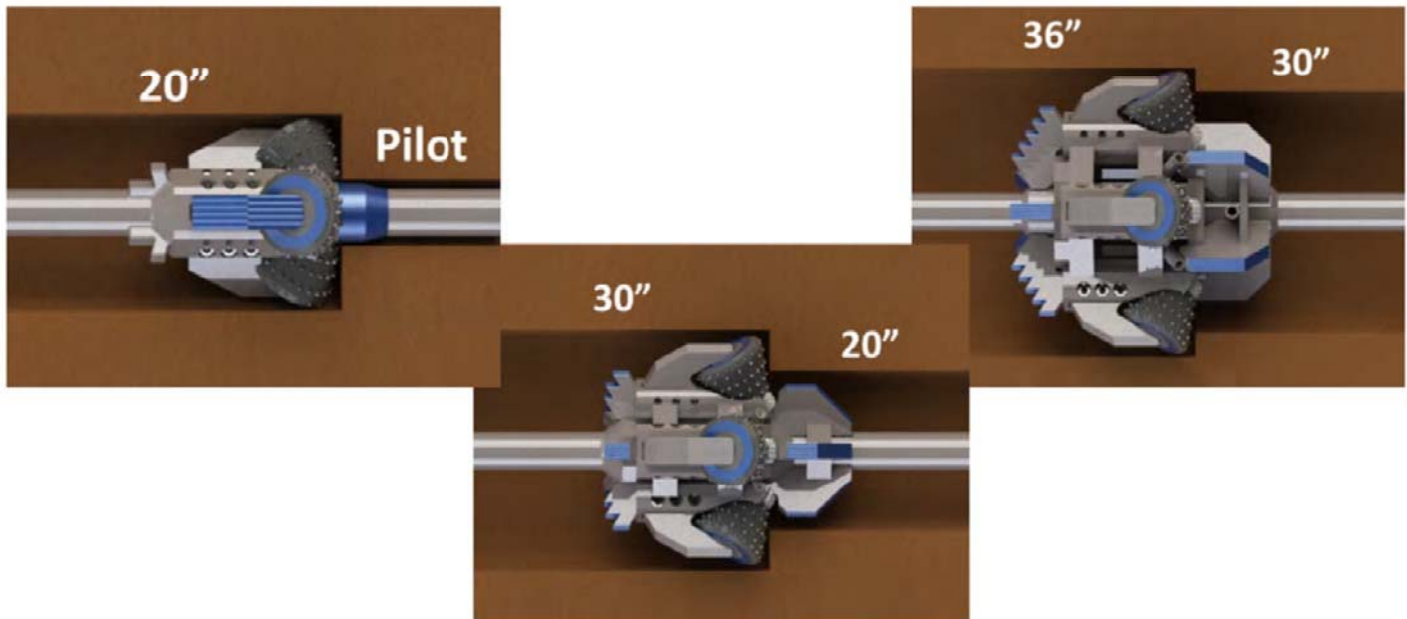

The Viper offers HDD contractors options that are not available with any other hole openers.

1. You can plan to utilize the exact same cutters on multiple size hole opening passes. Let's say 36" and 42". This can save the contractor the cost of a 42" hole opener.
2. You can design the Viper around tools and cutters you already own.
3. You can design around specific size increments, such as opening to 26", 36" and then 46".
4. One idea is to determine the total volume of formation being removed (using the chart on page 20), subtract the pilot hole volume and divide the balance by the number of passes. This balances the formation removed on each pass. Penetration rates should be similar, helping the driller make appropriate decisions.



FORMATION REMOVAL CHART

(Cubic Feet Per Foot Drilled)



OPENING DIAMETER "B"

	72	70	68	66	64	62	60	58	56	54	52	50	48	46	44	42	40	38	36	34	32	30	28	26	24	22	20	18	16	14	12	10	8	6	4	2
0	28.27	26.73	25.22	23.76	22.34	20.97	19.63	18.35	17.10	15.90	14.75	13.64	12.57	11.54	10.56	9.62	8.73	7.88	7.07	6.31	5.59	4.91	4.28	3.69	3.14	2.64	2.18	1.77	1.40	1.07	0.79	0.55	0.35	0.20	0.09	0.02
2	28.25	26.70	25.20	23.74	22.32	20.94	19.61	18.33	17.08	15.88	14.73	13.61	12.54	11.52	10.54	9.60	8.70	7.85	7.05	6.28	5.56	4.89	4.25	3.67	3.12	2.62	2.16	1.75	1.37	1.05	0.76	0.52	0.33	0.17	0.07	2
4	28.19	26.64	25.13	23.67	22.25	20.88	19.55	18.26	17.02	15.82	14.66	13.55	12.48	11.45	10.47	9.53	8.64	7.79	6.98	6.22	5.50	4.82	4.19	3.60	3.05	2.55	2.09	1.68	1.31	0.98	0.70	0.46	0.26	0.11	4	
6	28.08	26.53	25.02	23.56	22.14	20.77	19.44	18.15	16.91	15.71	14.55	13.44	12.37	11.34	10.36	9.42	8.53	7.68	6.87	6.11	5.39	4.71	4.08	3.49	2.95	2.44	1.99	1.57	1.20	0.87	0.59	0.35	0.15	6		
8	27.93	26.38	24.87	23.41	21.99	20.62	19.29	18.00	16.76	15.56	14.40	13.29	12.22	11.19	10.21	9.27	8.38	7.53	6.72	5.95	5.24	4.56	3.93	3.34	2.79	2.29	1.83	1.42	1.05	0.72	0.44	0.20	8			
10	27.73	26.18	24.67	23.21	21.79	20.42	19.09	17.80	16.56	15.36	14.20	13.09	12.02	11.00	10.01	9.08	8.18	7.33	6.52	5.75	5.04	4.36	3.73	3.14	2.60	2.09	1.64	1.22	0.85	0.52	0.24	10				
12	27.49	25.94	24.43	22.97	21.55	20.18	18.85	17.56	16.32	15.12	13.96	12.85	11.78	10.76	9.77	8.84	7.94	7.09	6.28	5.52	4.80	4.12	3.49	2.90	2.36	1.85	1.40	0.98	0.61	0.28	12					
14	27.21	25.66	24.15	22.69	21.27	19.90	18.57	17.28	16.04	14.84	13.68	12.57	11.50	10.47	9.49	8.55	7.66	6.81	6.00	5.24	4.52	3.84	3.21	2.62	2.07	1.57	1.11	0.70	0.33	14						
16	26.88	25.33	23.82	22.36	20.94	19.57	18.24	16.95	15.71	14.51	13.35	12.24	11.17	10.14	9.16	8.22	7.33	6.48	5.67	4.91	4.19	3.51	2.88	2.29	1.75	1.24	0.79	0.37	16							
18	26.51	24.96	23.45	21.99	20.57	19.20	17.87	16.58	15.34	14.14	12.98	11.87	10.80	9.77	8.79	7.85	6.96	6.11	5.30	4.54	3.82	3.14	2.51	1.92	1.37	0.87	0.41	18								
20	26.09	24.54	23.04	21.58	20.16	18.78	17.45	16.17	14.92	13.72	12.57	11.45	10.38	9.36	8.38	7.44	6.54	5.69	4.89	4.12	3.40	2.73	2.09	1.51	0.96	0.46	20									
22	25.63	24.09	22.58	21.12	19.70	18.33	17.00	15.71	14.46	13.26	12.11	11.00	9.93	8.90	7.92	6.98	6.09	5.24	4.43	3.67	2.95	2.27	1.64	1.05	0.50	22										
24	25.13	23.58	22.08	20.62	19.20	17.82	16.49	15.21	13.96	12.76	11.61	10.49	9.42	8.40	7.42	6.48	5.59	4.73	3.93	3.15	2.40	1.71	1.13	0.55	24											
26	24.59	23.04	21.53	20.07	18.65	17.28	15.95	14.66	13.42	12.22	11.06	9.95	8.88	7.85	6.87	5.93	5.04	4.19	3.38	2.62	1.90	1.22	0.59	26												
28	24.00	22.45	20.94	19.48	18.06	16.69	15.36	14.07	12.83	11.63	10.47	9.36	8.29	7.26	6.28	5.35	4.45	3.60	2.79	2.03	1.31	0.63	28													
30	23.37	21.82	20.31	18.85	17.43	16.05	14.73	13.44	12.20	11.00	9.84	8.73	7.66	6.63	5.65	4.71	3.82	2.97	2.15	1.40	0.68	30														
32	22.69	21.14	19.63	18.17	16.76	15.38	14.05	12.76	11.52	10.32	9.16	8.05	6.98	5.96	4.97	4.04	3.14	2.29	1.48	0.72	32															
34	21.97	20.42	18.92	17.45	16.04	14.66	13.33	12.04	10.80	9.60	8.44	7.33	6.26	5.24	4.25	3.32	2.42	1.57	0.76	34																
36	21.21	19.66	18.15	16.69	15.27	13.90	12.57	11.28	10.04	8.84	7.68	6.57	5.50	4.47	3.49	2.55	1.66	0.81	36																	
38	20.40	18.85	17.34	15.88	14.46	13.09	11.76	10.47	9.23	8.03	6.87	5.76	4.69	3.67	2.68	1.75	0.85	38																		
40	19.55	18.00	16.49	15.03	13.61	12.24	10.91	9.62	8.38	7.18	6.02	4.91	3.84	2.81	1.83	0.89	40																			
42	18.65	17.10	15.60	14.14	12.72	11.34	10.01	8.73	7.48	6.28	5.13	4.01	2.95	1.92	0.94	42																				
44	17.72	16.17	14.66	13.20	11.78	10.41	9.08	7.79	6.54	5.35	4.19	3.08	2.01	0.98	44																					
46	16.73	15.18	13.68	12.22	10.80	9.42	8.09	6.81	5.56	4.36	3.21	2.09	1.03	46																						
48	15.71	14.16	12.65	11.19	9.77	8.46	7.07	5.78	4.54	3.34	2.18	1.07	48																							
50	14.64	13.09	11.58	10.12	8.70	7.33	6.00	4.71	3.47	2.27	1.11	50																								
52	13.53	11.98	10.47	9.01	7.59	6.22	4.89	3.60	2.36	1.16	52																									
54	12.37	10.82	9.32	7.85	6.44	5.06	3.73	2.44	1.20	54																										
56	11.17	9.62	8.12	6.65	5.24	3.86	2.53	1.24	56																											
58	9.93	8.38	6.87	5.41	3.99	2.62	1.29	58																												
60	8.64	7.09	5.59	4.12	2.71	1.33	60																													
62	7.31	5.76	4.25	2.79	1.37	62																														
64	5.93	4.39	2.88	1.42	64																															
66	4.52	2.97	1.46	66																																
68	3.05	1.51	68																																	
70	1.55	70																																		

PILOT HOLE - DIAMETER "A"

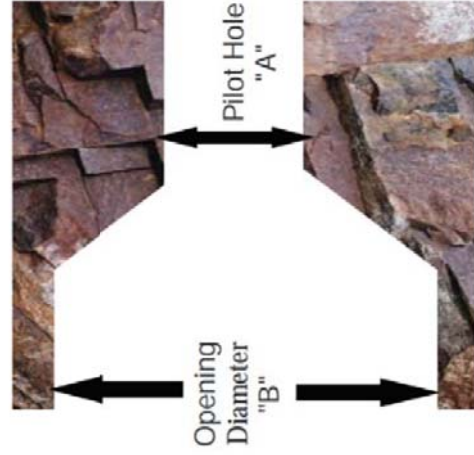

Bit Size	Cu.Ft. per Ft Drilled
8 1/2"	0.394
8 3/4"	0.418
9 7/8"	0.532
10 5/8"	0.616
11"	0.660
12 1/4"	0.818

Formation Transition; Getting Into the Rock

The transition from one formation to another is always an issue, specifically when moving from a soft formation into a hard one. The tool will naturally try and take the path of least resistance. Hole openers are designed to remove the formation from the forward plane. If the harder formation is off to the side or bottom, the rotating cutters are not contacting the formation as designed.

In this situation, the outer gauge inserts will be repeatedly striking the harder formation, with no balancing contact on any other part of the cutter face. The weight of the tool and the weight being applied by the drill rig are funneled to a single contact area at the outer gauge of the tool. Carbide inserts are extremely brittle. The flex of the drill pipe and restrictions of the pilot hole creates unequal torque, forcing the tool to bounce and chatter, damaging the gauge row of inserts very quickly. Pulling harder isn't the solution and it places the entire assembly in a greater bind and increases the damage to the outer gauge. The tool must be allowed to cut into the harder formation with an ever increasing ledge. The closer to 360 degrees the better, where normal hole opening methods can resume. At times, the damaged outer inserts will shorten the life of the hole opener, creating an under-gauge hole and slower ream times. If the situation is known, factoring the cost of an additional set of cutters for the transition is practical.

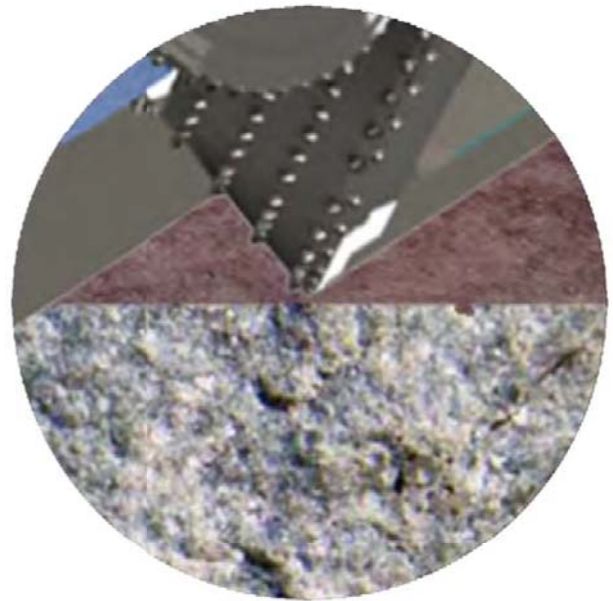

The situation can sometimes be improved by placing a near full gauge centralizer or the previous used hole opener directly in front of the hole opener in use. This can minimize the amount of room the current BHA can bounce or flex, increasing the force of the tool into the harder formation. Operate with as smooth a rotation as possible and allow the cutter to cut itself down into the harder rock, sometimes this method is called *time drilling*. Seating the larger diameter tool will be slow and may take multiple joints. Once set and shouldered up, trip out and remove the full gauge centralizer, before proceeding ahead with normal reaming operations.

The Use of Centralizers

Centralizers can benefit hole opening operations. A HTI bladed centralizer can assist in the removal of settled cuttings while improving hole opener operations in a number of ways. Keeping a tool squared up against the shoulder improves performance and extends cutter life. Sometimes the front of a hole opener centralizes itself and sometimes you will need a centralizer to move the hole opener up closer to a center point. In addition, a centralizer behind the tool can help keep the hole opener lined up, parallel with the pilot hole, improving performance.

The idea is to keep the hole opener close to the center of the pilot hole in order to have as even a cutting shoulder as possible. This keeps a more balanced load on the bearings, lowering torque and extending cutter life. Centralizers work well in vertical holes but a truly centralized hole opener in HDD isn't practical.

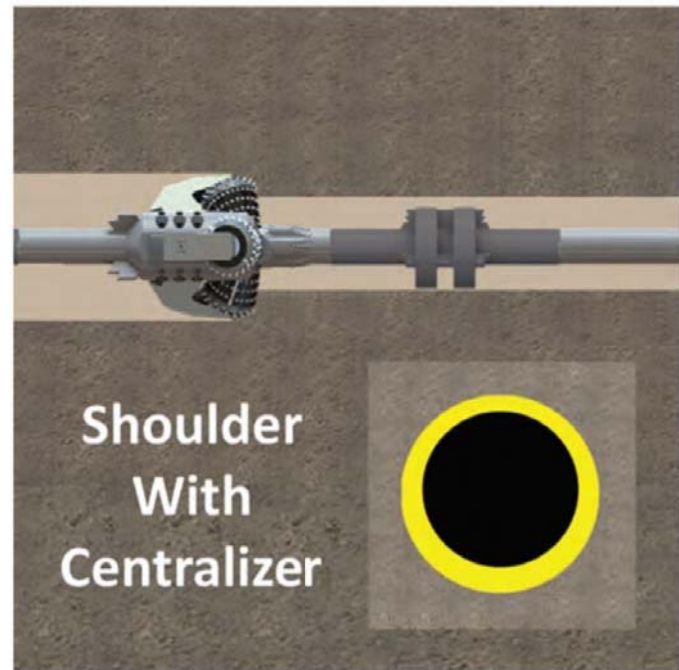
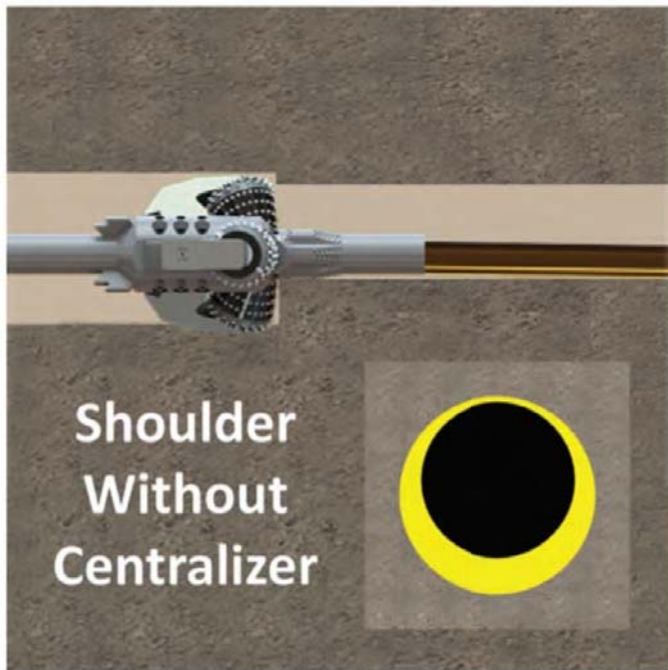

Horizontal holes are rarely without settled cuttings reducing the actual diameter of the opened hole. It isn't a good idea to use full gauge centralizers. The friction and grabbing from the outside of the hole on the centralizer creates drag and a difficult situation for the driller, masking actual weight and torque on the current hole opener in use. Centralizers should be under gauge; a couple inches on smaller diameters and even more for larger diameter tools.

Hole openers combined with centralizers can create a very stiff assembly. The closer the centralizer OD is to the gauge of the hole the stiffer the assembly. The chance of damaging or breaking a segment of the BHA is increased when maneuvering a too stiff assembly through a tight radius. It is a good idea to keep the centralizers sufficiently under gauge.



The larger the opening size the more likely a centralizer should be utilized. The drill pipe behind the hole opener will drop to the bottom of the hole. The larger the hole the further the drop. This creates a stress point, usually at the box of the drill pipe directly behind the reamer. As the pipe rotates, the stress is magnified by the continual flexing at the same bend point.

By placing a strategically sized centralizer a joint behind the hole opener, that bend and stress can be reduced. With or without the centralizer, this segment of drill pipe should be tagged and replaced regularly to prevent drill pipe failure or a twist off behind the hole opener.

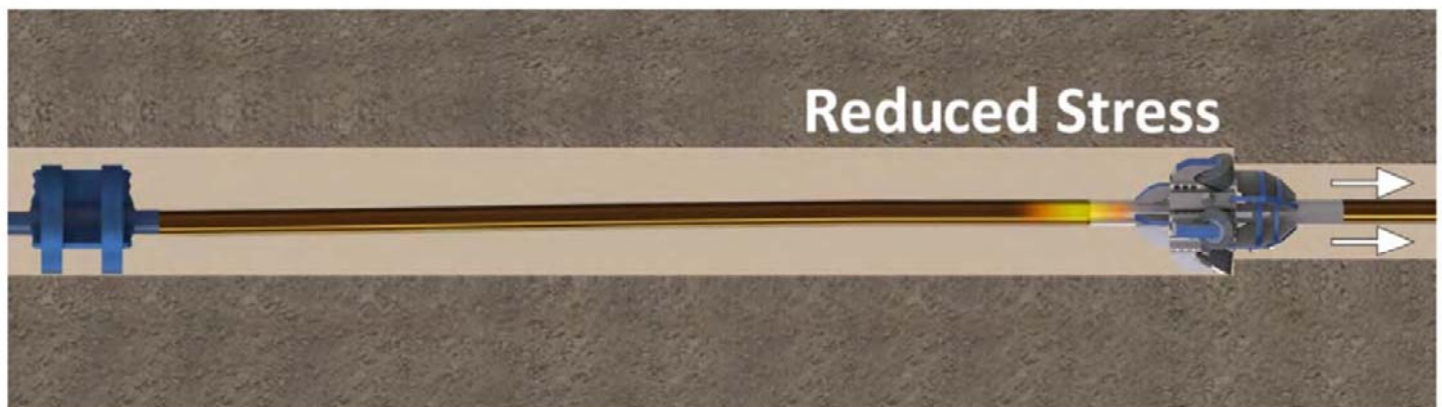

Problems with Centralizers

There are times when centralizers are necessary. There are also times they shouldn't be used.

Centralizers can create problems. When the hole isn't clean, and few are, the leading edge of the centralizer can create a wall or wave of cuttings, increasing the weight and torque needed to advance the reamer. If the centralizer rolls over the top of the cuttings, it can wedge against the top of the hole and hinder the operation. Keep this in mind when matching the centralizer diameter to the hole diameter.

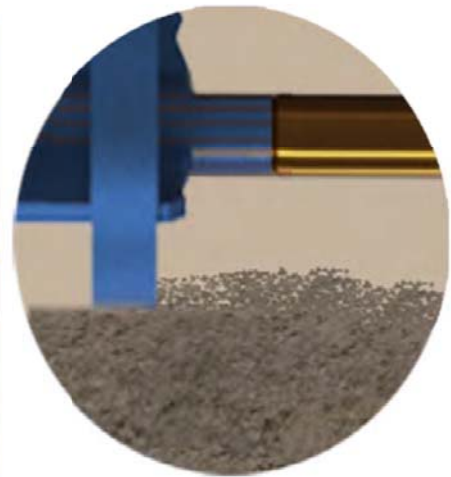
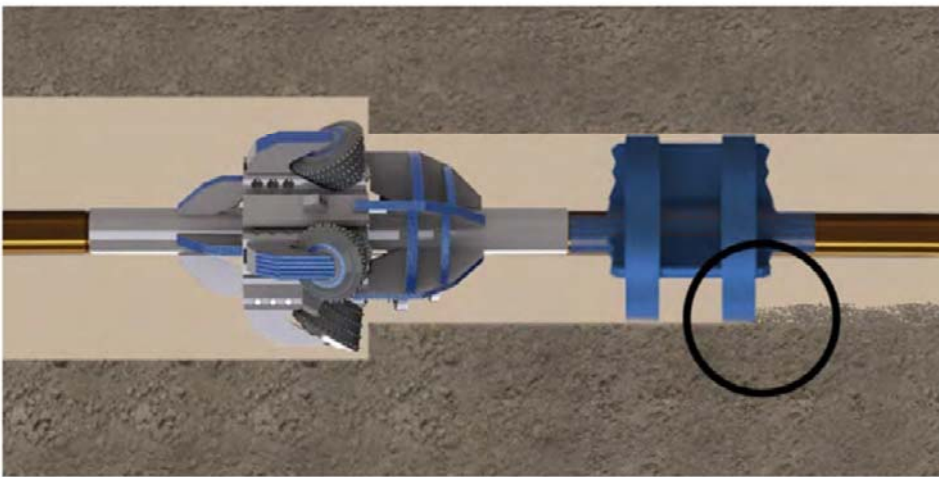

In some cases, specifically in changing or broken formations, the centralizer can hang up on a ledge or can cut its own ledge. If the penetration rate slows and more weight is required the problem may not be with the reamer but with the centralizer. This is a tough situation to analyze. This is an example where good records can help determine if the problem is the formation, the centralizer or the hole opener.

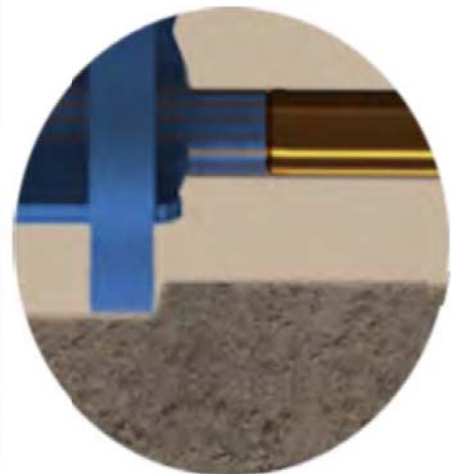
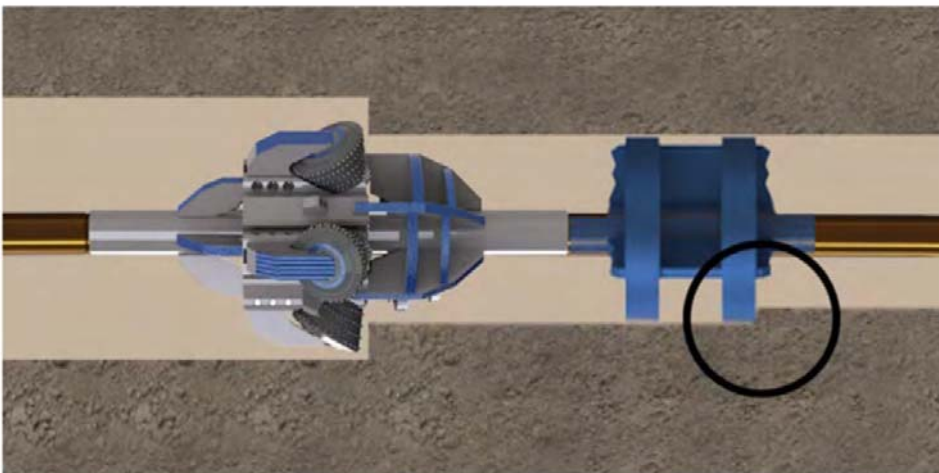



RockReamer

Field Adjustable Stabilizers



3 Bladed



4 Bladed

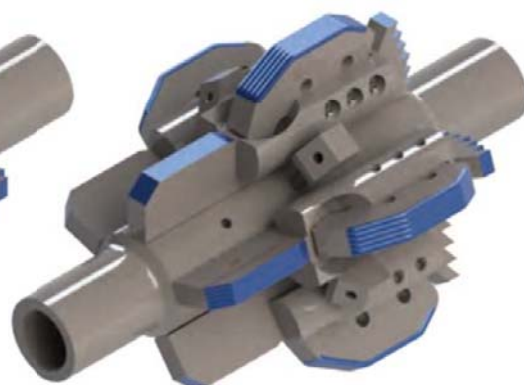

5 Bladed

BODY	NO. OF BLADES	MINIMUM PILOT HOLE	CONNECTION (Box x Box)	OD RANGE				
				aa	bb	cc	dd	ee
R6	3	6 ½"	3 ½ IF, 4 ½ IF	12"	14"	16"	18"	20"
R6-18	5	18"	3 ½ IF, 4 ½ IF	22"	24"	26"	28"	30"
R6-20	5	20"	3 ½ IF, 4 ½ IF	24"	26"	28"	30"	32"

BODY	NO. OF BLADES	MINIMUM PILOT HOLE	CONNECTION (Box x Box)	OD RANGE					
				A	B	C	D	E	F
R8	3	8 ½"	4 ½ IF, 5 ½ FH, 6 ½ FH	16"	18"	20"	22"	24"	26"
R17	3, 4	17 ½"	7 ¾ REG	24"	26"	28"	30"	32"	34"
R26	3, 5	26"	7 ¾ REG	32"	34"	36"	38"	40"	42"
R36	3, 5	36"	7 ¾ REG	42"	44"	46"	48"	50"	52"
R42	5	42"	7 ¾ REG	48"	50"	52"	54"	56"	58"
R48	5	48"	7 ¾ REG	54"	56"	58"	60"	62"	64"

Ringed Centralizers

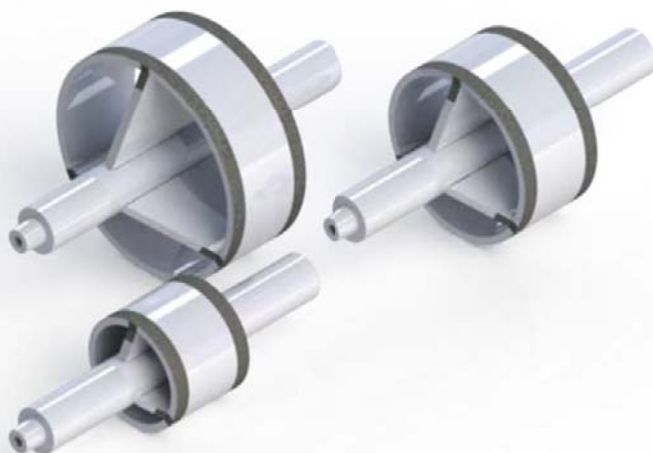

HTI offers a variety of centralizer designs. Select the one that matches your drill, your formation and your situation. Blade type tools are readily available in any size. Ringed tools may need to be manufactured so pre-planning is important.

Bladed style centralizers generally do a much better job of stirring settled cuttings from the bottom of the hole, increasing the percentage of cuttings circulated out of the hole. A cleaner hole improves hole opener performance and reduces tool wear.



Viper & Jumbo Viper RockReamers How To Change Cutters

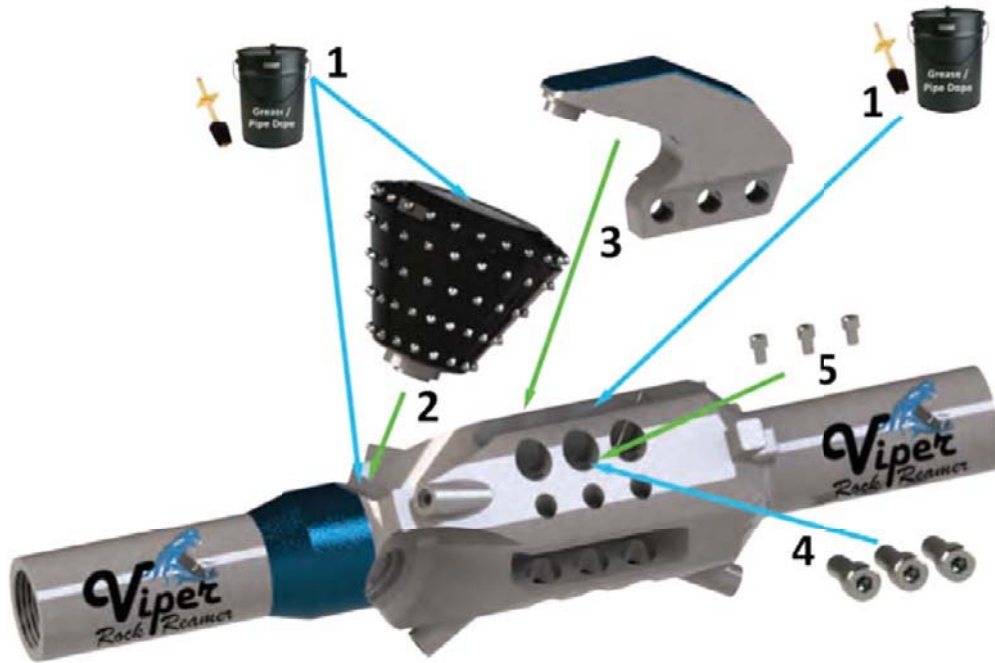

1. Apply grease / pipe dope on the top of cutter and in the pockets.
2. Place the correct size cutter into the pocket.
3. Slide the arm into place, securing the cutter.
4. Tighten the three bolts, according to chart below.
5. Tighten the three lock screws, according to chart below.
6. Repeat for each cutter.

Body Size	Bolt Size	Hex Key	Torque (ft./lbs.)	Lock Screw	Hex Key	Torque (ft./lbs.)
V4	¾ - 10 x 2 ½"	5/8"	400 - 500	⅜ - 16 x ½"	5/16"	40 - 60
V6	1 ⅞ - 7 x 3 ½"	7/8"	1,000 - 1,200	½ - 13 x ¾"	3/8"	100 - 150
V6-18						
V6-24						
V8						
V10						
V8-24	1 ½ - 6 x 5"	1"	2,000 - 2,500	¾ - 10 x 1"	5/8"	400 - 500
JV20						
JV26						
JV32						
JV38						
JV44						
JV50						
JV56						



PROJECTING CUTTER LIFE

Estimating the life for a hole opener is a losing proposition for a service company. Our competitors will always claim their tools will outlast ours. They don't, but that has never stopped them. The point is to help our customers budget and bid upcoming work. Yes, more than likely, our estimates will be conservative. They should be; it's your money.

It's impossible for us to tell you how long a hole opener will last without reviewing the specific details of each project. The best way is to use the pilot hole information as a guideline. This is where the Vipers' versatility comes in, allowing you to wait and then select the right tool. The one constant is that no matter what numbers we use, someone will tell you theirs will last longer or that our numbers are bogus. This can't be true because the resulting estimate will be based on your knowledge and experience. We understand providing these starting numbers will cost HTI business. That said, we believe it is our job to help you plan and the following estimates are meant to assist you with that plan. Don't use these numbers for anything except a feel for what you think exists below the ground and how the projected results match up with your knowledge and experience.

Everything is relative. What one person may call medium abrasive, another may consider very abrasive. What one contactor may call a dirty hole another may think is relatively clean. There are far too many variables and each drill is different. Elevation changes, rock properties, angles, hole design, mud programs, gravel, cobble, large cuttings, sand content, driller styles, rig sizes and a thousand other factors make these numbers nothing more than a topic of conversation.

Estimated Standard Cutter Life x Abrasive Factor x Hole Condition = Projected Life

1. Using the following charts match the opening cutter size with the formation PSI to establish a basis for cutter life in rotating hours.
2. If the formation is abrasive multiply by:

Slightly abrasive	0.90
Moderately abrasive	0.80
Very abrasive	0.65
3. If you expect a dirty hole multiply that answer by:

Slightly dirty hole (settled cuttings)	0.80
Moderately dirty hole (excessive cuttings)	0.70
Very dirty hole (cobble and/or gravel)	0.60

The answer is an estimated cutter set life for that size tool in those projected conditions.



Viper RockReamer

Mini & Midsize Rig Tooling



V6
6 1/2" Minimum Pilot

V6-18
18" Minimum Pilot

Estimated Cutter Life (Hours/Set)

Tool	Cutter / Size		4,000 PSI	8,000 PSI	15,000 PSI	20,000 PSI
			MT	TCI	TCI	TCI
V6 Minimum Pilot Hole: 6 1/2"	aa	12"	80	65	60	55
	bb	14"	85	70	65	65
	cc	16"	90	75	70	60
	dd	18"	90	80	75	65
	ee	20"	100	85	80	70

Tool	Cutter / Size		4,000 PSI	8,000 PSI	15,000 PSI	20,000 PSI
			MT	TCI	TCI	TCI
V6-18 Minimum Pilot Hole: 18"	aa	22"	80	65	60	45
	bb	24"	85	70	65	50
	cc	26"	90	75	70	55
	dd	28"	90	75	70	60
	ee	30"	100	85	80	70

Tool	Cutter / Size		4,000 PSI	8,000 PSI	15,000 PSI	20,000 PSI
			MT	TCI	TCI	TCI
V6-24 Minimum Pilot Hole: 24"	aa	28"	70	55	50	40
	bb	30"	75	60	55	45
	cc	32"	80	65	60	48
	dd	34"	80	65	60	52
	ee	36"	85	75	75	60



Viper RockReamer Large Rig Tooling



V8

8 1/2" Minimum Pilot

V10

10 5/8" Minimum Pilot

V8-24

24" Minimum Pilot

Estimated Cutter Life (Hours/Set)

Tool	Cutter / Size		4,000 PSI	8,000 PSI	15,000 PSI	20,000 PSI
			MT	TCI	TCI	TCI
V8 Minimum Pilot Hole: 8 3/4"	B	18"	90	80	70	65
	C	20"	100	90	80	70
	D	22"	105	100	90	80
	E	24"	110	105	95	85
	F	26"	115	110	100	90
	G	28"	120	115	105	100
	H	30"	125	120	110	105

Tool	Cutter / Size		4,000 PSI	8,000 PSI	15,000 PSI	20,000 PSI
			MT	TCI	TCI	TCI
V10 Minimum Pilot Hole: 10 5/8"	B	20"	100	90	80	70
	C	22"	105	95	85	75
	D	24"	110	100	90	80
	E	26"	115	110	95	85
	F	28"	120	115	100	90
	G	30"	125	120	105	95
	H	32"	130	125	110	100

Tool	Cutter / Size		4,000 PSI	8,000 PSI	15,000 PSI	20,000 PSI
			MT	TCI	TCI	TCI
V8-24 Minimum Pilot Hole: 24"	B	32"	90	80	70	65
	C	34"	100	90	80	70
	D	36"	105	100	90	80
	E	38"	110	105	95	85
	F	40"	115	110	100	90
	G	42"	120	115	105	100
	H	44"	125	120	110	105



Jumbo Viper

RockReamer
Large Rig Tooling



Estimated Cutter Life (Hours/Set)

Tool	Cutter / Size		4,000 PSI	8,000 PSI	15,000 PSI	20,000 PSI
			MT	TCI	TCI	TCI
JV20 Minimum Pilot Hole: 20"	JC	30"	192	176	154	148
	JD	32"	198	187	165	154
	JE	34"	209	192	170	159
	JF	36"	215	198	176	165

Tool	Cutter / Size		4,000 PSI	8,000 PSI	15,000 PSI	20,000 PSI
			MT	TCI	TCI	TCI
JV26 Minimum Pilot Hole: 26"	JC	36"	183	168	147	141
	JD	38"	189	178	157	147
	JE	40"	199	183	162	152
	JF	42"	205	189	168	158

Tool	Cutter / Size		4,000 PSI	8,000 PSI	15,000 PSI	20,000 PSI
			MT	TCI	TCI	TCI
JV32 Minimum Pilot Hole: 32"	JC	42"	180	165	144	136
	JD	44"	185	175	154	141
	JE	46"	195	180	159	148
	JF	48"	200	183	162	150

Tool	Cutter / Size		4,000 PSI	8,000 PSI	15,000 PSI	20,000 PSI
			MT	TCI	TCI	TCI
JV38 Minimum Pilot Hole: 38"	JC	48"	175	160	140	135
	JD	50"	180	170	150	140
	JE	52"	190	175	155	145
	JF	54"	195	180	160	150



Jumbo Viper

RockReamer
Large Rig Tooling



Estimated Cutter Life (Hours/Set)

Tool	Cutter / Size		4,000 PSI	8,000 PSI	15,000 PSI	20,000 PSI
			MT	TCI	TCI	TCI
JV44 Minimum Pilot Hole: 44"	JC	54"	172	156	137	131
	JD	56"	178	162	146	136
	JE	58"	185	170	150	141
	JF	60"	190	175	155	147

Tool	Cutter / Size		4,000 PSI	8,000 PSI	15,000 PSI	20,000 PSI
			MT	TCI	TCI	TCI
JV50 Minimum Pilot Hole: 50"	JC	60"	166	152	133	128
	JD	62"	171	161	142	133
	JE	64"	180	166	148	138
	JF	66"	185	171	152	142

Tool	Cutter / Size		4,000 PSI	8,000 PSI	15,000 PSI	20,000 PSI
			MT	TCI	TCI	TCI
JV56 Minimum Pilot Hole: 56"	JC	66"	157	144	126	121
	JD	68"	162	153	135	126
	JE	70"	171	158	140	130
	JF	72"	176	162	144	135

Without question the Viper and Jumbo Viper are far stronger than any split bit style tool. What factors should be considered when selecting tools for your project? When ready to enlarge a rock pilot hole, you have already invested a substantial amount of time and money. The harder the rock, the slower the drilling and the higher your costs; with that investment, what amount of risk are you willing to take?

If the job has been properly planned and bid, proven methods and procedures are your best ally. Avoid risks that could have disastrous consequences.

Obviously, you should never leave a hole opener in the ground too long. With a split bit, how long is too long? Many re-drills are due to lost cutters and the majority of HDD cutters lost are due to split bit failures.

The most common reason to risk using a split bit style hole opener is cost. However, the consequences of going cheaper can be devastating.

Comparing all factors usually reveals that split bits *aren't* less expensive. The fact that each tool must be bought and manufactured before drilling conditions are known, adds risk. Once built, split bit sizes and cutter styles cannot be adjusted. The versatility of the Viper hole opener allows the user to change cutter styles or opening sizes matching the project's needs. This feature eliminates down-time and can save thousands of dollars. The alternative to "buying in-advance" is possible down-time while waiting on the split bit's delivery. When ready, do you really want to put anything down-hole that was built in a hurry? Even if you build them yourself, the cost of inventory, assembly time and payroll are higher than choosing a ready to go Viper. Buy in advance or risk the wait, either way, split bit hole openers can raise bottom-line costs.



When placing a split bit hole opener down-hole, you also assume an increased risk of tool failure. A split bit hole opener is nothing more than tri-cone bit-thirds welded onto mandrels and plates. Split bit hole openers are common for water well drillers but seldom used in high dollar oil & gas drilling. An issue is that you seldom know the history of the bit, metallurgy of the body parts or if proper welding procedures were followed. Were the plates and mandrel of compatible steel, properly pre and post heated? Were the correct welding rods used? Were the bits from a pallet of buy backs or scraps, purchased at a junk-iron auction??



The tri-cone bit-thirds are created from roller cone bits separated by a cutting torch. Even if the bit-thirds were sold in segments to be welded as split bits, the segments must be welded when assembled. Heat damages steel, seals and bearings. In addition, the bit cones are relatively small and not designed to be used in larger tool diameter. The larger the opening diameter the faster the cone rotates on its own axis, increasing friction and the chance for bearing failure.

Oil & Gas drillers can't afford tool failure. Neither can HDD contractors, who often have their entire company invested. Split bit cones are held in place only by small steel bearings (Figure 1). As the inner cone and bearings wear, the cone can fall or pop off the shank (Figure 2). Often, this upcoming failure isn't even noticeable while applying weight and reaming with the split bit, as the cone is being pushed up towards the shank, but when you reverse direction, the cone can be pulled right off. Pulling a split bit

hole opener into the pit, only to see a missing cone or cones is devastating. Do you try and recover the missing down-hole cone or immediately re-drill the pilot hole? A choice no one ever wants but one that too many HDD contractors will face.

The Viper and Jumbo Viper are designed to improve cutter security. Viper cutters are not held in place by bearings (Figure 3). Viper's cutters are secured on both the top and bottom, by thick steel protected by layers of hard-metal, eliminating the chance of cutter loss with anything less than the occurrence of a major catastrophe.

In addition to massive cutter bearings, the Viper RockReamer utilizes a much larger diameter cutter, slowing cutter rotation at comparable RPM's, extending overall cutter life. The Viper is stronger, the cutters secured and the comparative RPM much lower, all resulting in better penetration rates and longer down-hole life.

Split bits are risky. Lost cones are devastating and so common that incidents are sometimes hidden or covered up. Due diligence dictates project managers require the best down-hole tooling. Without question, the Viper and Jumbo Viper will eliminate down-time and lower over-all risk.

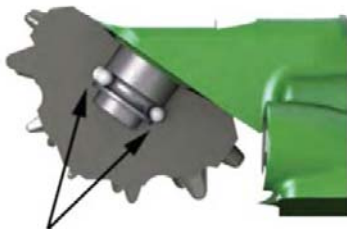

**Cutter held in place by bearings
(Figure 1)**



**Worn bearings
Equal lost cutter
(Figure 2)**

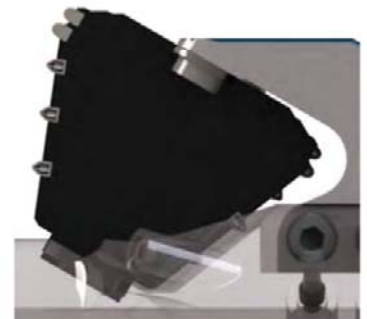

**Viper cutter secured
at top and bottom
(Figure 3)**

What about PDC, Fixed Blade Hole Openers?

There are two types of tools used for enlarging the hole, fixed and roller. The proper tool selection will depend on the formation as well as the rig being used. Fixed blade reamers, fluted reamers and fly cutters are similar in the fact that they have no moving parts. They are economical and work well in alluvial formations. This discussion applies to non-jetable, harder formations.

While HDD is a fairly new industry, commercial drilling tools have been around since the first oil well in 1859. This well was only about 70' deep but most oil wasn't that easy to find. Drilling through any rock was tough and hard rock was nearly impossible. Scrapping and scratching wasn't very efficient. To drill through harder formations, Hugh's Tool Company invented the roller cone bit in 1909. This allowed drillers to apply greater weights with less torque, improving penetration rates and lowering costs.

As oil and gas exploration drilled further and in deeper waters, factors changed. At greater depths, rigs and drilling equipment were more expensive, formations got harder and trip costs increased. In 1971, hard diamond discs (PDC) were applied to fixed blade bits. The idea is to shear rock with a continuous scraping motion, eliminating the risk of moving parts used in roller cone bits. PDC bits utilize synthetic diamond disks about 1/8-in. thick and about 1/2 to 1 in. in diameter. They are more effective in certain formations, especially when used in combination with oil-base muds. The longer zones in consistent formation combined with the more advanced drilling rigs improved ability to apply consistent weight, make PDC bits economical for deep well drilling.

That said, most oil & gas wells are still drilled with roller cone bits. The use of PDC hole openers is even more rare.

PDC (Polycrystalline Diamond Compact) isn't new technology unless you consider 45 years as new. PDC has been around longer than the cell phone or personal computer. In fact, PDC bits have been around longer than HDD, so it isn't new technology. PDC bits were tried early on in River Crossing applications but contractors quickly returned to roller cone bits because they improved penetration and were far easier to steer. Mechanically, roller cone drilling tools are far superior to the fixed blade options; the larger the diameter the greater the advantage.

Although the Viper has massive size bearings to lower drill string torque and allow the driller to apply the weight needed, Horizontal Technology, Inc. does have replaceable and adjustable fixed blade hole opener cutters to fit the RockReamer bodies (**Pictured**). These fixed blade arms are dressed with very tough carbide disc that work well in certain formations and are far less expensive than diamonds. The tools can be dressed to any size. We have sold a number of these to HDD contractors in Australia where they have a high percentage of sandstone formations. They worked well. However, the same contractors who have used these fixed bladed tools usually returned to roller

cone hole openers because of lower torque and better penetration rates. We try and keep all sizes of fixed blade hole openers on the shelf. If you think a fixed blade tool is what's best for your project, we can supply any size you need.

Why are there so many PDC bit salesmen in the HDD market? It's simple; anyone who can semi-weld or lay a bead of hard metal can create or repair a PDC bit. PDC bits are literally being built in mom and pop garages and warehouses from coast to coast. This is another issue, PDC bits come in a wide variety of insert styles, layouts, profiles and sizes, engineered for specific formations and rigs. Does the PDC salesman calling on you look like a drilling engineer or a peddler?

Most PDC bit success stories tend to be in softer formations when drilled with very high GPM. This is even truer with PDC hole opener operations, specifically in Canada where cobble and broken rock are commonly in a matrix of alluvial soils. The actual results are based on the excessive GPM, not the PDC. The same result would likely be accomplished with any tool, fixed or roller cone, if accompanied by the same GPM. In fact, as the harder formations are encountered the roller cone bit would reduce torque and the likelihood of twisting off. Of course, this is why HDD contractors utilize roller cone tools to begin with. Torque increases with diameter. Not only are PDC hole openers ridiculously expensive they increase the risk of twisting off. In most cases, if you can utilize a PDC you could use a far cheaper fixed blade tool with the same results.

Another issue is push vs. pull. Unlike roller cone cutters, fixed blade tools are manufactured to cut in one direction. If you are pulling the hole opener towards the rig you cannot turn the same cutters around and push away from the rig.

With fixed blade hole openers, you will be forced to take smaller bites; therefore, increasing the number of passes. The larger the hole diameter, the greater the cost. In addition, the larger the diameter the greater the torque and the likelihood you will stall, if not snap, the drill string.

While PDC tooling will continue to be pushed on the HDD industry, the new Viper roller cone hole openers will continue to be the industry work horse, especially in hard formations.



Replaceable Fixed Blade Viper



NEW VIPER ROCKREAMER RESETS HDD STANDARDS

Three Unique Projects Highlight Durability Versatility & Value

By: Horizontal Technologies Inc.

Horizontal Technology Inc.'s new Viper RockReamer is designed in part to alleviate the epidemic of split-bit reamers catastrophically losing cutters down-hole. The Viper provides added strength and the best possible down-hole cutter security in addition to longer hours, smoother rotation and better penetration rates. This amazing HDD tool is the compilation of decades of down-hole tool experience, engineering and HDD customer input. From 8 3/4-inch to 72-inch, the Viper is now on the shelf and ready to go, offering a variety of features to benefit drilling contractors.

Right after it was introduced, three, unique, out-of-the-box, projects highlighted the new Viper's durability, flexibility and direct economic value. There couldn't have

been more challenging tests. The Viper offered solutions in these real life circumstances, providing bottom line economic benefits to the HDD contractors.

Project #1 - Durability:

Drilling 1,500 LF of parallel 32-inch and 36-inch lines in 30,000 PSI granite with high quartz content was the equivalent of taking final exams on the first day. Final hole sizes of 48 inches and 54 inches had to be completed in some of the world's toughest rock.

The 32-inch line was first and the 8 3/4-inch pilot hole times confirmed the hard formation reports with some joints taking up to 5 hours. Because the Viper is designed to allow greater weights with less torque, the decision was made to do passes of 24-inch,

36-inch and 48-inch passes - big bites out of a hard formation like this! The Viper is designed with the largest bearing capacity of any HDD tool ever used. This reduces torque, allowing the operator to increase weight which improves the penetration rate with less stress on the rig. The V8 with 24-inch TCI cutters were pulled towards the rig and the performance exceeded expectations. The reaming times matched the pilot hole even though almost five times the amount of formation was being removed. After about 57 reaming hours the Viper and the 24-inch cutters still looked great so the reaming continued.

The next pass used a five cutter, JV-20 Jumbo Viper dressed with 36-inch TCI cutters. Getting the large bite to shoulder up in such hard formation would take a few joints.

Basically the tool was bouncing on the harder rock, just inching its way down while being pulled towards the rig. After the tool shouldered up many of the gage inserts were damaged. To avoid reaming an under gage hole the 36-inch was opened with a new set of TCI cutters. Although removing about 40% more formation than the 24-inch, the Viper's 36-inch penetration rates remained about the same. The performance through hard rock was impressive.

The next pass used the original 36-inch in tandem, just ahead of the JV-32 Jumbo Viper dressed with 48-inch TCI cutters. The idea was to stiffen the reaming assembly and centralize the 48-inch helping it transition into the rock until fully shouldered up. This worked much better as the tool was allowed to cut its way down, eventually shouldering up across the full 360 degrees. At that point the 36-inch Viper was removed and the 48-inch pass proceeded.

Although the amount of formation being removed was again substantially greater, the penetration rates weren't much slower. This was attributed to the Jumbo Viper five cutter design, the increased bearing capacity and the skills of the driller. The tool was being rotated at the right RPM to ensure maximum penetration rates with the matching pull weight. A good mud program kept as clean a hole as possible and the combination allowed the Viper to perform as designed.

With the experience from the first drill, the second finished even quicker. Was it



possible to "one up" the first accomplishment by going to 54-inch in three passes? The 28-inch, 42-inch and 54-inch plan was ready before the second pilot hole was completed. The great thing about Viper RockReamers is the versatility – sizes can be changed simply by adjusting the body size and cutter size. This saves contractors money and avoids down time.

The Viper's first test couldn't have been better, an incredible success. The Viper cutters lasted longer than any cutter anyone had ever seen. Some runs were in the 150 hour range with the cutters appearing to have many hours left. The entire project was completed ahead of schedule and the contractor used less than a third of the hole openers expected.

Project #2 - Versatility:

The second project, consisting of 6 bores totaling almost 14,000 LF, demonstrated another aspect of the Viper's advantage to

HDD contractors. The plan was to drill 12 1/4-inch pilot holes and then open to 26-inch, 36-inch, 46-inch, 58-inch and possibly 64-inch. The contractor estimated that reaming would take about 6,000 hours and more than 61 hole openers would be needed to bore through what was expected to be an extremely hard formation. Even the smallest split-bits were in the \$50,000 range and the largest approached \$150,000 for each tool. Millions would be spent just on hole openers alone.

Rigs and equipment were mobilized and the pilot holes began, encountering only hard clay and shale, none of the very hard formation projected. Wow – this was an extreme change from the conditions expected! What now? Every hole opener on the job site was TCI but the proper cutter style for these conditions was MT. Before the first pilot hole was even finished the TCI cutters were replaced with MT, at no cost to the contractor or downtime waiting for the appropriate tooling.

The Viper's ability to adjust cutter styles to match the formation meant that the 26-inch, 36-inch 46-inch and 58-inch tools already on site could be converted quickly and easily. And this wasn't the final change. The actual drilling factors dictated multiple changes in the planned hole opening sizes: from pilot hole to 26-inch, 40-inch and then a reduced final hole size of 54-inch. To further complicate the situation, some segments did require a combination of interchangeable MT and aggressive TCI cutters.

All these adjustments were made at no cost to the contractor. A high percentage of the project costs were related to hole openers. With the Viper, the contractor saved by not having to buy 64-inch hole openers (up to 17 had been projected) and didn't have to



buy the 58-inch either. The cost of each size would have ranged around \$150,000 per tool.

The Viper allowed the contractor to use the same cutters on a variety of bodies creating different size openers with already purchased cutters. Numerous sets of cutters were used in the 100 hour range and not a single set of arms were damaged. In addition to its outstanding down-hole performance, the Viper enabled the contractor to adjust to changing conditions without delays or down time.

Project #3 – Value:

A 60-inch sewer line required a 72-inch final hole opening pass in limestone, two drills totaling about 4,000 LF. Milled tooth HDD hole openers of 30-inch, 42-inch, 54-inch, 66-inch and 72-inch were necessary. Based on the projected hours, at least two tools of each of the five sizes would be required, built in advance to prevent expensive down time.

Instead of having to buy ten expensive split bit hole openers, the Viper gave the ability to use the same cutters on multiple size passes. The cutters from the 42-inch were reused on the 66-inch. The cutters from the 54-inch were used again on the 72-inch. After this, the same cutters were taken off the larger tools and placed back on the 42-inch and 54-inch for the second drill. One cutter set had over 160 hours and another set finished with just under 200 hours. Both were still in relatively good condition and could have gone further and longer.

Three unique projects, three tough tests demonstrating the new Viper RockReamer durability and flexibility - all resulting in tremendous savings for the HDD contractors, and dramatically raising the HDD hole opening standard. The Viper RockReamer is the latest and greatest in the evolution of HDD hole openers.

According to John English, President of Horizontal Technology Inc., "The best engineers & the best HDD rock drillers have

had a major impact on the design of this tool. The Viper RockReamer has improved the hole opening capabilities of the entire HDD industry."

ABOUT THE AUTHOR:



John English, President of HTI has worked with, and on, roller cone reaming tools since 1977, starting with Grant Oil Tools. He first became involved in horizontal hole openings for river crossings in 1988 and found the drilling conditions were far different than vertical hole opening. The harsh conditions dictated design changes. With Kent Rives he built the first custom HDD hole opener using the "Q" cutters in 1990. This evolution continued with the variable sized Lo-Torque in 1994 and then the more versatile, stronger, RockReamer in 1998. These improvements continue today, as HTI celebrates 20 years serving the HDD industry.

Drill Collar Connection Make-Up Torque														
Connection		Minimum Make-Up Torque (lb-ft)												
		OD (Inch)	ID (inch)											
Size	Type		1 1/4	1 1/2	1 3/4	2	2 1/4	2 1/2	2 13/16	3	3 1/4	3 1/2	3 3/4	
2 3/8	Reg	3	2241	2241	1749									
		3 1/8	3028	2574	1749									
		3 1/4	3285	2574	1749									
	IF	3 1/2	4606	4606	3697									
2 7/8	Reg	3 1/2	3838	3838	3838									
		3 3/4	5766	4951	4002									
		3 7/8	5766	4951	4002									
	IF	3 7/8	4640	4640	4640	4640								
3 1/2	Reg	4 1/8	6466	6466	6466	6466	5685							
		4 1/4	7886	7886	7886	7115	5685							
		4 1/2	10471	9514	8394	7115	5685							
	IF	4 3/4			9986	9986	9986	9986	8315					
4 1/2	Reg	5 1/2			15576	15576	15576	15576	15576					
		5 3/4			20609	20609	20609	19601	16629					
		6			25407	23686	21749	19601	16629					
	IF	6 1/4			25407	23686	21749	19601	16629					
5 1/2	FH	6 1/4					23004	23004	23004	23004	23004			
		6 1/2					29679	29679	29679	29679	26675			
		7					32762	32762	32762	32762	32762			
		7 1/4					40998	40998	40998	40998	40998			
6 5/8	Reg	7 1/2					49661	49661	47756	45190	41533			
		7 3/4					54515	51687	47756	45190	41533			
		8						46399	46399	46399	46399			
	IF	8 1/4					55627	53346	50704	46936				
7 5/8	Reg	8 1/4					57393	53346	50704	46936				
		8 1/2					57393	53346	50704	46936				
		8 3/4					67789	67789	67789	67789	67789	67789	67184	
		9					79544	79544	79544	76706	72102	67184		
7 5/8	Reg	9 1/4					88582	83992	80991	76706	72102	67184		
		9 1/2					88582	83992	80991	76706	72102	67184		
		8 1/2					60402	60402	60402	60402	60402	60402		
		8 3/4					72169	72169	72169	72169	72169	72169		
7 5/8	Reg	9					84442	84442	84442	84221	79536	74529		
		9 1/4					96301	91663	88580	84221	79536	74529		
		9 1/2					96301	91633	88580	84221	79536	74529		



HT HORIZONTAL TECHNOLOGY INC.



*16863 Warren Ranch Road
Hockley, Texas 77447
United States of America
Toll Free: 888-556-5511
Tel: 713-774-5594*

*31 Manitoba Way
Spruce Grove, AB T7X 0V5
Canada
Tel: 780-955-0233*

*Website: www.horizontaltech.com
Email: info@horizontaltech.com*