

# HDD's Best



**Rugged Power,  
Dependable Performance**

---

*Motor & Bit  
Handbook*

---

Horizontal Technology, Inc.

---



## Table of Contents

Page 1	Drilling Motor Introduction
Page 2	Drilling Motor Design - Top Sub / Safety Catch
Page 3	Drilling Motor Design - Power Section
Page 4	Drilling Motor Design - Power Section Elastomers / Coupling Section
Page 5	Drilling Motor Design - Bearing Section / Bit Box
Page 6	HDD Drilling Motor Applications
Page 7	Motor Pre-Operation Procedures
Page 8	Making Up The Motor
Page 9	Adjusting The ABH
Page 10	ABH Recommended Torque Values
Page 11	Checking Thrust Bearing Wear / Flow Test The Motor
Page 12	Downhole Drilling Operations
Page 13	Drilling Reference - Off Bottom Pressure
Page 14	Pressure While Drilling / Stall Pressure
Page 15	Tripping Out Of The Hole / Maintenance Procedures After Tripping
Page 16	Motor Specifications - 3 3/4" 9/10 Lobe 4 Stage
Page 17	Motor Specifications - 4 3/4" ~ 3-3/4" 9/10 Lobe 4 Stage Sonde Motor
Page 18	Motor Specifications - 4 3/4" 9/10 Lobe 2 Stage
Page 19	Motor Specifications - 4 3/4" 9/10 Lobe 2 Stage Sonde Motor
Page 20	Motor Specifications - 6 3/4" 9/10 Lobe 2 Stage
Page 21	Motor Specifications - 6 3/4" 9/10 Lobe 2 Stage Sonde Motor
Page 22	Motor Specifications - 8" 9/10 Lobe 4 Stage
Page 23	Motor Trouble Shooting
Page 26	Jetting Assembly
Page 27	Bit Reference Charts
Page 28	Drill Collar Connection Make-Up Torque



16863 Warren Ranch Road  
Hockley, Texas 77447  
United States of America  
713-774-5594

Toll Free: 888-556-5511  
[www.horizontaltech.com](http://www.horizontaltech.com)  
[info@horizontaltech.com](mailto:info@horizontaltech.com)

31 Manitoba Way  
Spruce Grove, AB T7X0V5  
Canada  
780-955-0233



16863 Warren Ranch Road  
Hockley, Texas 77447  
U.S.A.

Phone: (713) 774-5594  
Fax: (713) 466-7552  
Toll Free: (888) 556-5511  
[www.horizontaltech.com](http://www.horizontaltech.com)  
[info@horizontaltech.com](mailto:info@horizontaltech.com)

## Drilling Motor Introduction

The drilling motor (Figure 1) is a hydraulically actuated device that converts hydraulic energy into mechanical energy. For HDD purposes, the primary purpose of the drill motor is to provide a mechanism allowing the operator a way to re-direct/steer the drill bit by virtue of a bend located behind the bit sub. The motor provides rotational speed (RPM) and torque directly to the bit with or without rotation of the drill pipe. The drilling motor takes the energy from a succession of isolated working fluid volumes that force their way, under pressure, through the motor by displacing or deforming the spaces in which they are confined.

HDD Contractors originally used motors built and designed for Oilfield work. Recognizing a difference in application, Horizontal Technology Inc. (HTI) was the first HDD service company to begin customizing drilling motors to fit River Crossing operations. While many of these changes remain proprietary, we are proud of our motor design and the influence our changes have made in the continuing HDD motor evolution.

Our shorter motors improve steering. New power sections have been engineered and designed to provide maximum torque at minimal GPM. The bit to bend improvement strengthens the motor while allowing contractors tighter radius capabilities. Improved alloys reduce rotor wear and better rubber compounds improve the power and life of the stator. Horizontal Technology Inc.'s HDD motors are designed for strength and durability, matching the needs of today's HDD contractors.

The primary focus of this handbook is to assist in explaining drilling applications, motor selection, and operations. This handbook includes information on the following topics:

- Drilling Motor Design
- Drilling Motor Applications
- Drilling Motor Operation
- Troubleshooting Charts
- Drilling Motor Specifications



*Figure 1*



16863 Warren Ranch Road  
Hockley, Texas 77447  
U.S.A.

Phone: (713) 774-5594  
Fax: (713) 466-7552  
Toll Free: (888) 556-5511  
[www.horizontaltech.com](http://www.horizontaltech.com)  
[info@horizontaltech.com](mailto:info@horizontaltech.com)

## Drilling Motor Design

The HTI motor is a positive-displacement motor (PDM). As drilling fluid is pumped down the drill string, the fluid flows through the cavities in the power section. The fluid pressure reacts against the lobes of the rotor and the walls of the stator causing the rotor to rotate. Torque is then transmitted through the coupling section, bearing section, and down to the drill bit.

The HTI drilling motor is comprised of 6 basic components:

- Top Sub
- Safety Catch
- Power Section
- Coupling Section
- Bearing Section
- Bit Box

Figure 2 is a cutaway view of the entire motor with these basic components identified.

### **Top Sub**

A top sub, or crossover sub as it is sometimes called, is used to attach the motor to the drill string. The crossover sub typically has a standard API box connection that connects to the drill string and a proprietary pin connection that connects to the motor. In some cases, top subs may also be designed as a combination top/safety catch sub.

### **Safety Catch**

The safety catch provides the ability to remove the motor from the well in the unlikely case of a motor connection failure. This component can help prevent a fishing operation on a broken down-hole motor. The safety catch is sometimes part of the top sub.

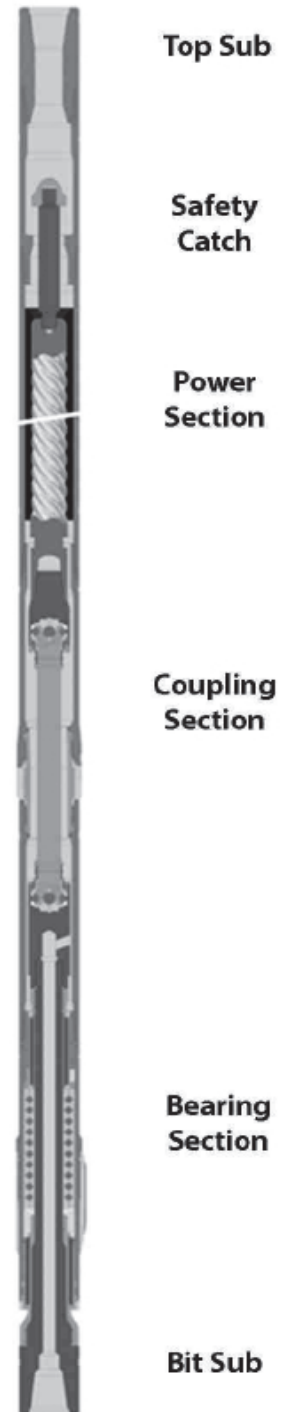

*Figure 2*





## Power Section

The power section is the part of the motor that converts hydraulic energy into mechanical energy, resulting in drill-bit rotation. The power section consists of two parts, the rotor and the stator (see Figure 3). When assembled, these two components form a continuous seal along their contact points.

The rotor is a high carbon alloy steel bar with a machined helical (multi-lobed) pattern. It is then chrome plated to reduce wear and corrosion.

The stator is a length of tubular steel called a 'can' that is lined with a rubber compound called the 'elastomer'. The elastomer is formed with a helical (multi-lobed) pattern similar to that of the rotor. The difference between the stator and the rotor is that the stator will have one more lobe than the rotor. Since the stator always has one more lobe than the rotor, the ratio of the rotor lobes (X) to the stator lobe (X+1) is usually designated as (X):(X+1). For example: 1:2, 3:4, 5:6, 7:8, 9:10, etc.

## Power Section Cross-Sections

Referencing the image to your right, the power section cross-section (or profile) shows different lobed rotors inside their corresponding stator. The power section profiles are designed with these different ratios to allow for specific motor speeds and torques. Motor speed can be easily changed just by changing the rotor/stator lobe ratio. Generally, the higher the number of rotor/stator lobes yields a power section with a slower speed and higher torque. Fewer rotor/stator lobes yields a power section with a higher speed and lower torque.

16863 Warren Ranch Road  
Hockley, Texas 77447  
U.S.A.

Phone: (713) 774-5594  
Fax: (713) 466-7552  
Toll Free: (888) 556-5511  
[www.horizontaltech.com](http://www.horizontaltech.com)  
[info@horizontaltech.com](mailto:info@horizontaltech.com)

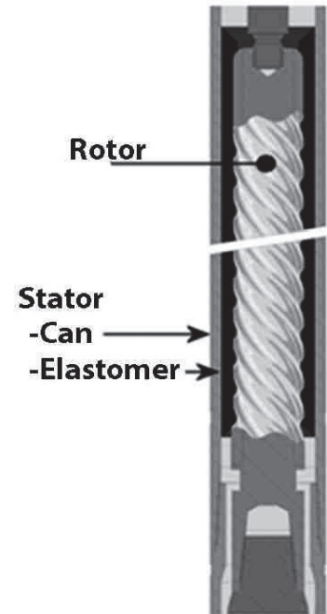

Figure 3



Figure 4



## **Power Section Elastomers**

HTI utilizes a high-performance, high durometer compound elastomer that forms the internal profile of the stator. Designed to meet the most demanding applications, the premier performance stator's elastomer is a hard rubber formulation with excellent mechanical properties.

## **Coupling Section**

The coupling section comprises of two components: the internal coupling and the external coupling housing.

The coupling (see Figure 5) attaches the lower end of the rotor to the upper end of the drive shaft. The coupling transmits the rotational speed and the torque from the rotor to the drive shaft. In addition, the coupling converts the eccentric (side to side) motion of the rotor to the concentric (in line) motion of the drive shaft. The coupling is precision machined for smooth articulation and minimal wear while providing optimum torque to the drill bit.

The coupling housing encases the coupling within the motor. The coupling housing provides an optimum location for the placement of a bend in the motor. Adding a bend to the coupling housing makes the motor a steerable tool. Coupling housings can have either a fixed bend or a series of adjustable bend angles. Housings with adjustable bend angles typically have a range from either 0° - 3° and are easily adjustable at the rig site.

16863 Warren Ranch Road  
Hockley, Texas 77447  
U.S.A.

Phone: (713) 774-5594  
Fax: (713) 466-7552  
Toll Free: (888) 556-5511  
[www.horizontaltech.com](http://www.horizontaltech.com)  
[info@horizontaltech.com](mailto:info@horizontaltech.com)

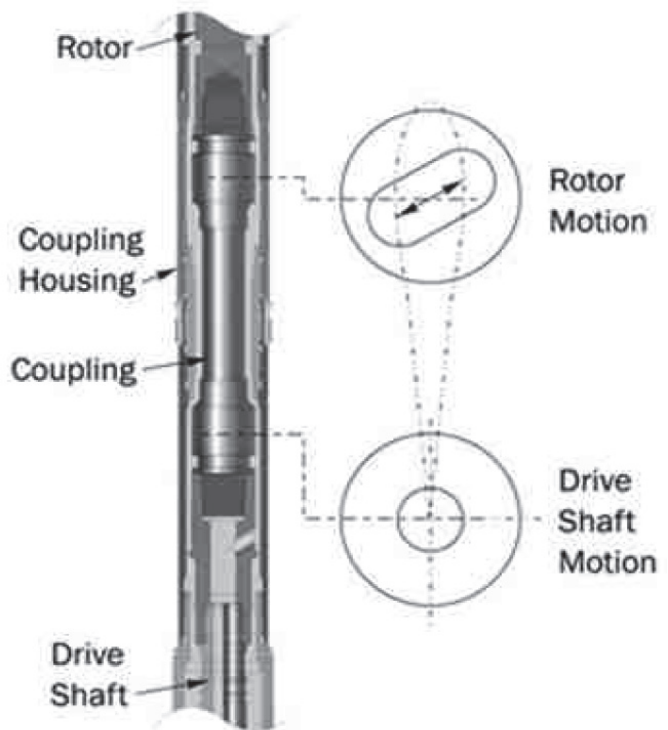

*Figure 5*



## Bearing Section

The bearing section makes up the lower half of the motor. It is comprised of a drive shaft that is supported by a series of radial and thrust bearings. The bearing section is what controls the mechanical energy supplied by the power section to the drive shaft. The drive shaft transfers this energy to the drill bit through the bit box. Drilling parameters, such as weight on bit (WOB), circulation rate, and bit differential pressure directly affect the bearing section.

The HTI bearing section is an open bearing design (i.e. the bearings are lubricated by the drilling fluid). HTI uses a stacked multiple ball and race design for the thrust bearings (see Figure 6). An open bearing system offers the advantage of allowing higher differential pressures across the drill bit over a traditional sealed bearing arrangement.



Figure 6

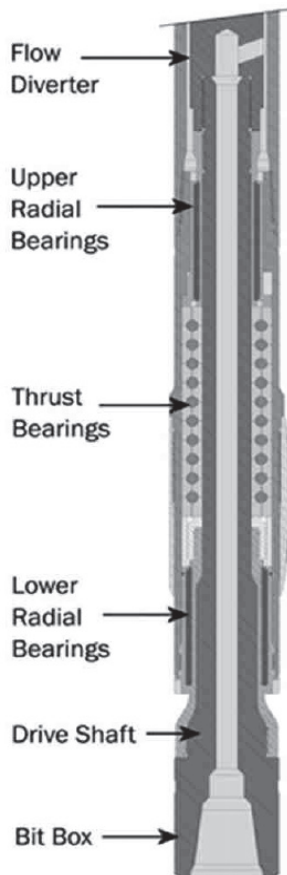

Figure 7

The thrust bearings support the downward force resulting from the weight on the drill bit (WOB) and the loads from the combined hydrostatic thrust and weight from the internal motor components.

Radial bearings support the side loads on the drive shaft and help regulate the flow of drilling fluid through the bearing assembly. Some of the drilling fluid is diverted to cool and lubricate the bearings. HTI uses radial bearings with tungsten carbide tile inserts which are imbedded in a tungsten carbide matrix for maximum wear resistance from side loads.

### Bit Box

The drill bit attaches to the motor at the bit box. For added strength and durability, the bit box is integrated to the drive shaft. HTI motors incorporate a safety device that connects the lower radial bearing onto the upper half of the bit box. This helps to provide additional security against leaving the bit in the hole in the unlikely event the drive shaft were to break internally. The bit box typically is machined with an API Regular Box (internal) thread.

16863 Warren Ranch Road  
Hockley, Texas 77447  
U.S.A.

Phone: (713) 774-5594  
Fax: (713) 466-7552  
Toll Free: (888) 556-5511  
[www.horizontaltech.com](http://www.horizontaltech.com)  
[info@horizontaltech.com](mailto:info@horizontaltech.com)



16863 Warren Ranch Road  
Hockley, Texas 77447  
U.S.A.

Phone: (713) 774-5594  
Fax: (713) 466-7552  
Toll Free: (888) 556-5511  
[www.horizontaltech.com](http://www.horizontaltech.com)  
[info@horizontaltech.com](mailto:info@horizontaltech.com)

## HDD Drilling Motor Applications

The primary function of a drilling motor in the HDD industry relates to steering. The ability to adjust the drill bits direction at any time or away distance is a prerequisite of any HDD pilot hole.

While a motor can be straight, the vast majority of motors used in HDD have a bend. This bend is what allows the operator to maneuver the bit in a specific direction. The pressured flow of drilling fluids pumped through the drill pipe, generate rotation via the power section of the motor which, in turn, rotates the bit. By advancing/pushing the non-rotating drill pipe, the rotating bit will create a hole, diverted in the direction of the motor's bend. This is commonly called sliding. Once the desired direction is obtained, the entire drill string can be rotated to improve productivity, until the next correction is required.

Sliding, or steering, slows penetration rates. Productivity is enhanced while rotating the drill pipe. The increased bit rotation provided by a motor when added to a rotating drill pipe will enhance performance and productivity while reducing pipe wear. By turning the drill bit several times faster than the drill string, a motor can effectively provide an increased rate of penetration (ROP). Since the motor is providing the rotation to the drill bit, rotational speed (RPM) of the drill string can be significantly reduced from standard rotary drilling speeds.

Horizontal Technology, Inc.'s downhole motors offer considerable operational and economic benefits. Benefits from drilling with a HTI motor include:

- Faster Rate of Penetration (ROP)
- Reduced Drilling Times
- Reduced Drill String Rotational Speeds (RPM)
- Less Wear and Fatigue of Drill String Connections
- Less Drill String Torque
- Maximum Horse Power with Lower GPM
- Tighter Turn Capabilities Improve Rotation Ratios







16863 Warren Ranch Road  
Hockley, Texas 77447  
U.S.A.

Phone: (713) 774-5594  
Fax: (713) 466-7552  
Toll Free: (888) 556-5511  
[www.horizontaltech.com](http://www.horizontaltech.com)  
[info@horizontaltech.com](mailto:info@horizontaltech.com)

HTI Currently offers two basic types of steerable motors: Adjustable Bend Housing and Fixed Bend Housing.

### ***Adjustable Bend Housing***

Motors with Adjustable Bend Housings (ABH) utilize a bend in the coupling housing. This is the most common type of steerable motor. The bend in the motor creates an offset in the axis of the bit relative to the axis of the hole. The bend is generally an angle between 0 and 3 degrees. The biggest advantage of an Adjustable Bend Housing is the ability to adjust the bend at the job site. The ability to make a tighter or faster turn without waiting on or using a second motor can save time and money

### ***Fixed Bend Housing***

Motors with a fixed bend housing operate exactly as those with an ABH. The advantage is fewer parts and potentially lower repair bills.

## **Drilling Motor Design**

### ***Motor Selection***

It is important to select the right motor to match the project. Factors include rig size, pump capabilities, cleaning system, drill pipe, bit size/type, formation, drill length, needed bend to match designed radius, estimated penetration rates, final hole size, and reaming plan.

### ***Motor Pre-Operation Procedures***

Performance and efficiency will be enhanced by proper operation within the parameters defined in the specific tool selections. Follow the recommended procedures for motor operation.

***Caution: Safety glasses, steel toed shoes, and a hard hat must be worn while performing any of the following procedures. All applicable rig, work site, and/or transportation safety procedures must be followed. Lifting and torque equipment should be checked and safety procedures must be followed. Lifting and torque equipment should be checked for ratings and operational condition per appropriate specifications before using.***



16863 Warren Ranch Road  
Hockley, Texas 77447  
U.S.A.

Phone: (713) 774-5594  
Fax: (713) 466-7552  
Toll Free: (888) 556-5511  
[www.horizontaltech.com](http://www.horizontaltech.com)  
[info@horizontaltech.com](mailto:info@horizontaltech.com)

## Making Up the Motor

1. Use adequate and proper amounts of pipe dope on all connections. Make up the drill bit to the motor using the bit connection recommended torques. While making up connection, try to avoid damaging the motor by only placing tongs or vices on the motor bit box.

HDD Bit Specifications		
(INCH)	API Connection	(FT/LB)
4 5/8 - 5	2 7/8 REG	4500 - 5500
5 1/8 - 7 3/8	3 1/2 REG	7000 - 9000
7 1/2 - 9 3/8	4 1/2 REG	12000 - 16000
9 1/2 - 14 3/8	6 5/8 REG	28000 - 32000

**Caution: If a bit crossover sub or thread adaptor is used, the overall length of the sub should be only long enough to accept make-up tongs (Recommend max is 10 inches or 254 mm). Greater lengths may damage or reduce bearing life and/or cause the drive shaft to break resulting in the loss of the sub and the bit in the hole.**

2. If the motor is not newly dressed from the shop but has been unused for an extended period of time, it is recommended that the following steps be taken to break-in the motor before us:

Place vices or make-up tongs on the coupling housing and slowly rotate the bit sub a couple of turns to the right.

**Note: Do not place tongs on the bearing assembly as this may pinch the internal components and could prevent the motor from turning.**

3. Make-up the motor to the orientation sub, sonde housing, or crossover connection at the lower end of your drill string. Be sure the connections are tightened to the specified torque. It is a good idea to use a punch or hammer to mark the connection with the motor and steering tool housing in order to troubleshoot possible orientation problems.

Do not thread joints into the motor top sub by rotating the motor with tongs. This could result in unthreading the tool's internal joints.

To avoid unthreading internal joints, the bit box should only be turned to the right.

HTI Motors will be shipped with the bent housing ordered by the client. If changes are needed and the motor is equipped with an ABH, the bend can be adjusted on site.



16863 Warren Ranch Road  
Hockley, Texas 77447  
U.S.A.

Phone: (713) 774-5594  
Fax: (713) 466-7552  
Toll Free: (888) 556-5511  
[www.horizontaltech.com](http://www.horizontaltech.com)  
[info@horizontaltech.com](mailto:info@horizontaltech.com)

## Adjusting the ABH (if equipped)

Setting the adjustable bend housing is a fairly simple operation. Below is the procedure for setting the HTI adjustable bend housing:

1. Tong in the areas as shown in Figure 9  
**Do not place tongs on the orientation sleeve.**
2. Break apart the ABH connection.
3. Unthread the lower ABH housing, 2 to 4 complete turns

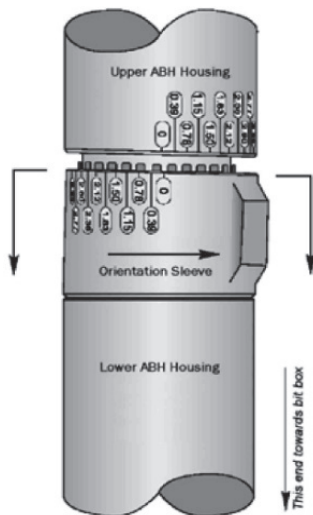

Figure 10

4. Referencing Figure 10, left, slide the Orientation sleeve down to disengage the interlocking teeth.
5. To adjust the bend angle, rotate the Orientation Sleeve (no more than 1/2 turn in either direction) until the desired bend angle mark is in line with the identical bend mark on the Upper ABH Housing.
6. Referencing Figure 11 (bottom right), slide the Orientation Sleeve upward so that the interlocking teeth are fully engaged.
7. Check to see if the desired bend angle marks on both the Upper ABH Housing and the Orientation Sleeve are in line.
8. Apply thread dope to the bottom face of the Orientation Sleeve.  
**Caution: Do not use thread locking compound on the ABH Connections.**
9. While keeping the Orientation Sleeve fully engaged in the Upper ABH Housing, thread the Lower ABH Housing until it shoulders against the Orientation Sleeve.
10. Tong in the areas shown in Figure 9 and apply the appropriate torque to the connection. See the table on next page for recommended ABH torque values.

11. The bend angle marks on the Upper ABH Housing and the Orientation Sleeve that match and are in line with each other tell the angle of the ABH. In addition, these matching and in line bend angle marks indicate the high side of the tooling.

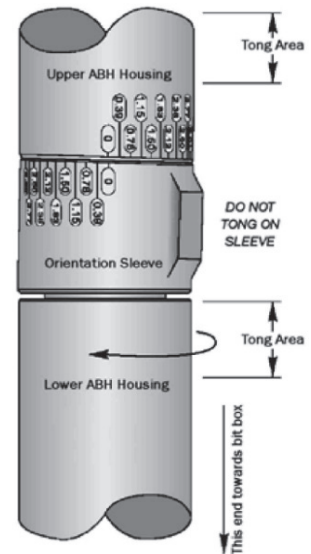

Figure 9

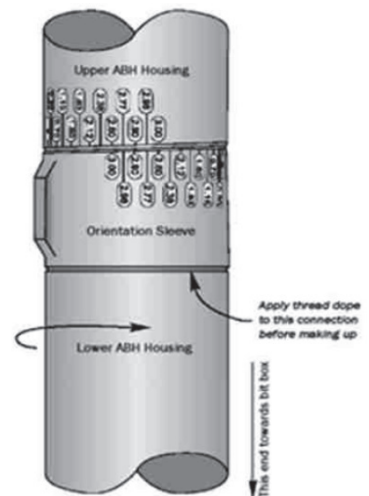

Figure 11



16863 Warren Ranch Road  
Hockley, Texas 77447  
U.S.A.

Phone: (713) 774-5594  
Fax: (713) 466-7552  
Toll Free: (888) 556-5511  
[www.horizontaltech.com](http://www.horizontaltech.com)  
[info@horizontaltech.com](mailto:info@horizontaltech.com)

### Adjustable Bend Housing (ABH) Recommended Torque Values

Motor OD	English	Metric
3 3/4" (375)	4600 ft-lb	6237 Nm
4 3/4" (475)	7000 ft-lb	9491 Nm
6 3/4" (675)	30000 ft-lb	40675 Nm
8" (800)	37000 ft-lb	50165 Nm

### ABH Angle Mark identification Guide

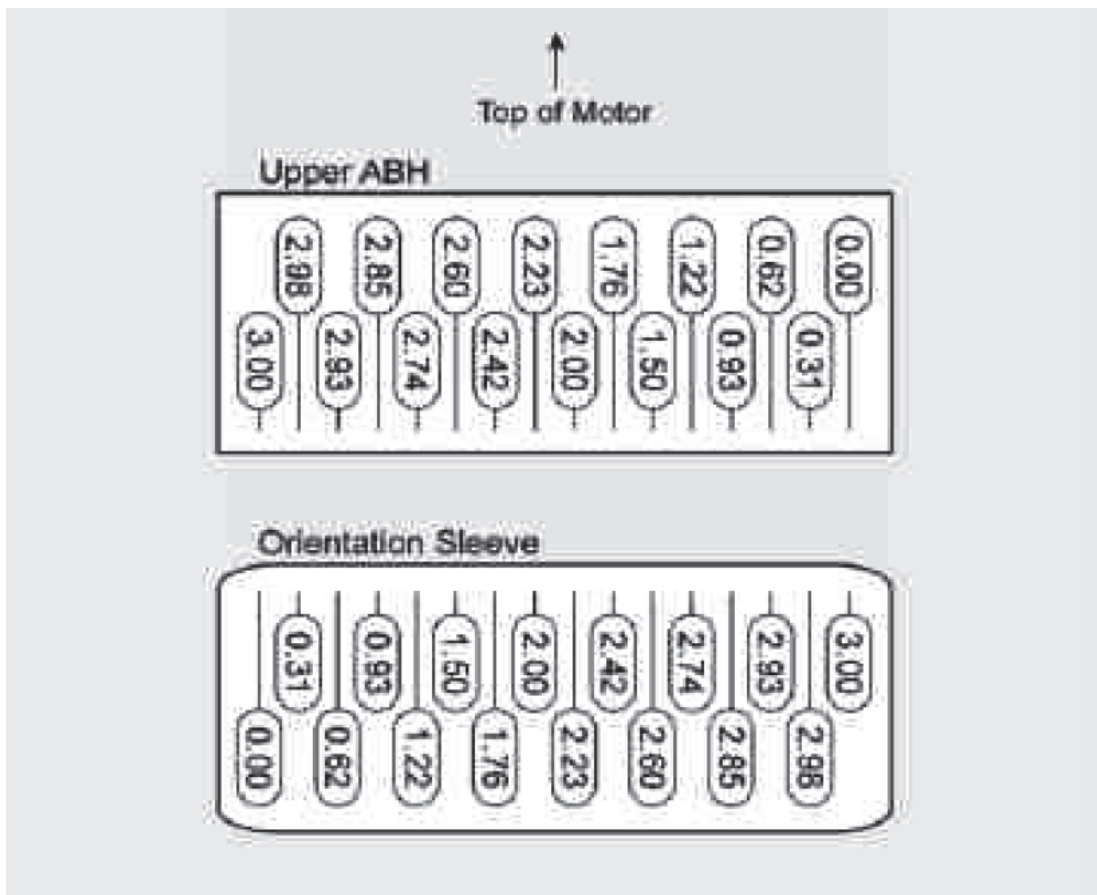





16863 Warren Ranch Road  
Hockley, Texas 77447  
U.S.A.

Phone: (713) 774-5594  
Fax: (713) 466-7552  
Toll Free: (888) 556-5511  
[www.horizontaltech.com](http://www.horizontaltech.com)  
[info@horizontaltech.com](mailto:info@horizontaltech.com)

### Checking Thrust Bearing Wear

It is recommended, prior to re-running a used motor in the hole, to check the thrust bearings for wear. Thrust bearing wear can be determined easily by the amount of play the drive shaft has between the back face of the bit box and the end of the bearing housing. The following describes how to check the amount of play the bit box has.

1. While out of the hole and in front of the rig, rotate the bit by engaging pump pressure for a few bit rotations, then shut off the pump. Referencing Figure 12, take a measurement (L1) between the bottom of the bearing housing and the top of the bit box.
2. Slowly lower the motor until the bit makes contact with a fixed resistance, perhaps a skid against an excavator bucket. Take a measurement (L2) at the same location.
3. To determine the thrust bearing wear, subtract L1 from L2.
4. Please contact HTI if the difference exceeds the allowed wear in the chart.

### Thrust Bearing Check

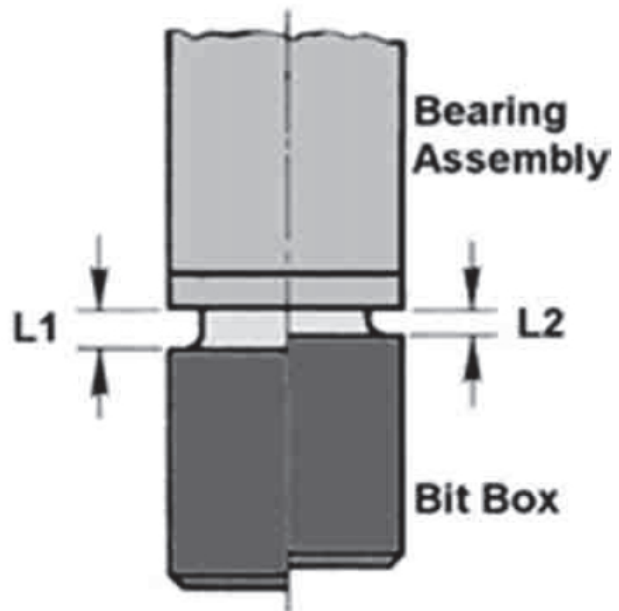

Figure 12

### Allowable Bearing Wear L1 - L2

Motor OD	English	Metric
3 3/4" (375)	0.12 in	3.05 mm
4 3/4" (475)	0.12 in	3.05 mm
6 3/4" (675)	0.18 in	4.57 mm
8" (800)	0.25 in	6.35 mm

### Flow Testing the Motor

1. Start the rig pumps, Use minimum flow for the first few revolutions, then increase slowly, as needed.
2. Raise the motor far enough to visually check that the bit sub is rotating and the tool is operational. Keep the test as short as possible.



16863 Warren Ranch Road  
Hockley, Texas 77447  
U.S.A.

Phone: (713) 774-5594  
Fax: (713) 466-7552  
Toll Free: (888) 556-5511  
[www.horizontaltech.com](http://www.horizontaltech.com)  
[info@horizontaltech.com](mailto:info@horizontaltech.com)

## ***Motor Tripping Recommendations***

### ***Tripping Into the Hole***

While the HTI drilling motor is a reliable tool, any motor can be susceptible to damage if care is not taken when tripping. The following are recommendations for tripping the motor into the hole:

- Maintain positive pump pressure while tripping
- Pay attention to and notate off bottom drill pipe pressures
- Always reduce tripping speed when nearing turns in the bore path
- Trip at a controlled rate to avoid damage
- An increase in the drill pipe pressure could indicate the bit is encountering an undrilled formation
- The motor and the bit will trip differently in hard rock versus softer formations
- Take the time to re-drill through any tight spots

***Caution: To avoid sidetracking, pay close attention to directional data and pilot hole location. Reduce tripping speed when approaching the last 60 - 90 feet of hole, as there may be cuttings/fill in the bottom of the hole or the pipe.***

### ***Drilling Considerations***

Avoid stalling the motor. Stalling will cause damage to the motor. The performance and life of the motor are determined by the environment in which it is operated. To ensure optimum performance and the longevity, avoid the following:

- Abrasive solids in the circulating system  
(the use of drill pipe screens is highly recommended)
- Pumping higher than recommended fluid volume
- Exceeding recommended weight on bit (WOB) loads
- Exceeding the recommended pressure drop across the bit and the motor
- Repeated stalling of the motor





16863 Warren Ranch Road  
Hockley, Texas 77447  
U.S.A.

Phone: (713) 774-5594  
Fax: (713) 466-7552  
Toll Free: (888) 556-5511  
[www.horizontaltech.com](http://www.horizontaltech.com)  
[info@horizontaltech.com](mailto:info@horizontaltech.com)

## Flow Rates

The recommended minimum/maximum flow rate for each motor should be observed to achieve optimum torque and tool life. Flow rates for each HTI drilling motor are given in this Motor Handbook. It is recommended that before the motor reaches the bottom of the hole, the flow rate should be started at the minimum rate and then slowly increased to the recommended operating range.

**Caution: Exceeding the recommended flow rates could potentially damage the motor.**

## Drilling Reference

The HTI motor is a hydraulically operated tool. Therefore, the primary reference is the rig pressure gauge. The weight indicator can also be used as a drilling reference; however, it may give inaccurate information about the actual WOB because of potential drag and restrictions, especially during sliding operations. In this case, the only true indication of whether the bit is on bottom drilling is the pressure gauge. Refer to Figure 13 for off-bottom, drill-off, and stall-out conditions that are discussed in the following sub-sections.

### Off-Bottom Pressure

When the motor is off-bottom circulating, the standpipe pressure gauge shows the total amount of pressure required to pump a known volume of fluid through the drilling system. This is called 'off-bottom' pressure.

Output torque is directly proportional to the pressure drop across the motor and is indicated as a change in total system pressure. Motor differential pressure is defined as the pressure above off-bottom pressure.

*Note: When the bit is side loaded due to an adjustable bent housing, off-bottom pressure will include the motor pressure to provide torque to rotate the bit with the imposed side load. This can occur in a tight radius or with higher degree bends. True motor differential pressure is obtained from standpipe pressure only when the bit is not side-loaded or when system pressure losses, without the motor, are known.*

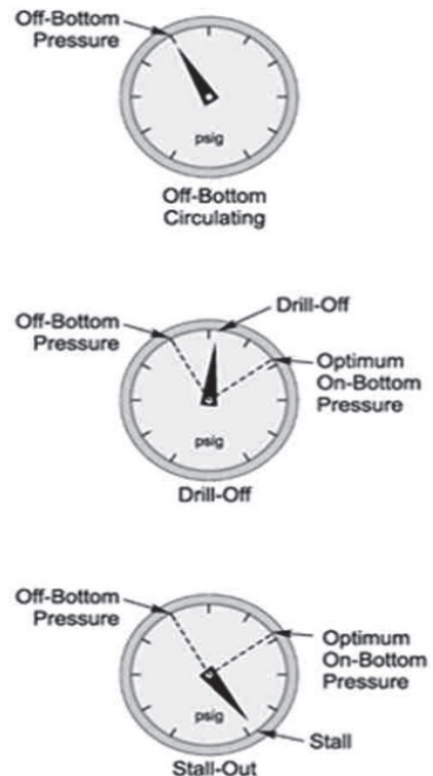

Figure 13



16863 Warren Ranch Road  
Hockley, Texas 77447  
U.S.A.

Phone: (713) 774-5594  
Fax: (713) 466-7552  
Toll Free: (888) 556-5511  
[www.horizontaltech.com](http://www.horizontaltech.com)  
[info@horizontaltech.com](mailto:info@horizontaltech.com)

As it applies to HDD applications, many believe that the rotation of the drill string and motor bend will create an oversized hole, in comparison to the bit diameter. This oversized hole is possible in softer formations, but unlikely in hard rock. In hard formations, the bend of the motor will rotate with the drill string within the diameter of the hole.

Larger bends, in hard formations, specifically with smaller bits, will create excessive wear on the kick pad and the bent housings, increasing damage and reducing motor hours.

### ***Pressure While Drilling***

More WOB means a higher pressure at the surface. As the bit drills off, the total system pressure decreases. Therefore, the standpipe pressure gauge can be used as an indicator of bit weight as well as torque. Drill pipe friction will not cause a distortion of the readings. When the pressure gauge reads the optimum on-bottom pressure and the driller subsequently stops adding weight to the bit, a drill-off occurs. The pressure will steadily fall until the driller puts more weight on the bit. Performance curves and recommended differential pressures for the HTI motor are included in this handbook.

### ***Stall Pressure***

When enough WOB is added to exceed the maximum differential pressure of the motor, a stall will occur. The backpressure of the drilling fluid will cause the elastomer in the motor's power section to deform. This results in the drilling fluid to flow straight through the motor without causing the bit to turn. The pressure gauge will rise, spike abruptly, and then remain stationary, even if more weight is added to the bit. Stall pressure is typically about twice the recommended optimum differential pressure across the motor.

***When a stall occurs, turn the mud pumps off and allow the standpipe pressure to bleed off. After bleed off, carefully raise the bit off bottom slightly to allow for any torsional wrapping of the drill string to slowly unwind. Normal drilling procedures may commence once the drill pipe has been completely unwound.***

***Caution: Operating in a stalled condition, even for a short period of time, can seriously damage the motor. Stalling can lead to tearing or 'chunking' of the stator elastomer. Once a stator is chunked, motor performance will dramatically decrease or possibly the motor could cease to function.***





16863 Warren Ranch Road  
Hockley, Texas 77447  
U.S.A.

Phone: (713) 774-5594  
Fax: (713) 466-7552  
Toll Free: (888) 556-5511  
[www.horizontaltech.com](http://www.horizontaltech.com)  
[info@horizontaltech.com](mailto:info@horizontaltech.com)

### ***Tripping Out of the Hole***

The following are recommendations for tripping out of the hole:

- Maintain positive pump pressure while tripping.
- Always reduce tripping speed when nearing turns.
- Control tripping speed to enhance swabbing the hole.
- Avoid excessive back-reaming as it may shorten motor life.

### ***Maintenance Procedures After Tripping***

If to be left on location, the following post-run maintenance steps are required after tripping out of the hole:

1. If possible, flush the motor with clean water.
2. After removing from the drill string, drain remaining fluid from the motor by rotating the bit to the right. This is important in cold climates as a freeze could damage the motor.
3. Apply pipe dope to all exposed connections.

## 3-3/4" Mud Motor 9/10 Lobe 4 Stage

Motor Specifications	English	Metric
Model Number	375-910-4	
Motor Size	3.75 in	95.25 mm
Rotor / Stator Lobes	9 / 10	
Stages	4	
Length	15.8 ft	4.8m
Weight	440 lb	199.5 kg
Operating Flow Rate	60-140 GPM	227-530 LPM
Maximum Developed Power	33 hp	25 kW
Maximum Developed Torque	1,550 ft-lb	2,100 N-m
Speed @ No Load	78-183 RPM	
Revs Per Volume @ No Load	1.31 Rev/Gal	0.34 Rev/L
Differential Pressure @ No Load	200 psi	1378.9 kpa
Speed @ Full Load	50-150 RPM	
Revs Per Volume @ Full Load	1.07 Rev/Gal	0.28 Rev/L
Differential Pressure @ Full Load	600 psi	4,136.8 kpa
Bit to Bend	45 in	1143 mm
Maximum Pressure Drop	1,500 psi	10,342 kpa
Maximum Weight on Bit	12,000 lb	53 kN
Maximum Pull to Re-Run Motor	70,000 lb	266 kN
Pull to Yield Motor	200,000 lb	890 kN
Bit Box Connection	2-7/8 Reg	
Upper Box Connection	2-7/8 Reg	

Build Rate (Degrees Per 100 Feet)				
ABH Angle	Hole Size			
	4 3/4"	5"	5 1/2"	5 7/8"
0.35				
0.69	4.35	2.47		
1.04	9.08	7.20	3.50	0.78
1.37	13.54	11.65	7.94	5.22
1.69	17.87	15.97	12.25	9.52
2.00	22.06	20.16	16.42	13.68
2.29	25.98	24.07	20.33	17.58
2.57	29.86	27.87	24.10	21.34
2.83	33.28	31.36	27.60	24.83
3.06	36.39	34.47	30.69	27.93
3.28	39.36	37.44	33.66	30.88
3.46	41.80	39.87	36.08	33.30
3.63	44.09	42.16	38.37	35.59
3.76	45.85	43.92	40.12	37.33
3.86	47.20	45.27	41.47	38.68
3.94	48.29	46.35	42.55	39.75
3.98	48.83	46.89	43.08	40.29
4.00	49.10	47.16	43.35	40.56

Flow Rate	* Rev/Gal
60 GPM	0.83
105 GPM	1.00
150 GPM	1.07

\* At Full Operating Load

PERFORMANCE CURVE

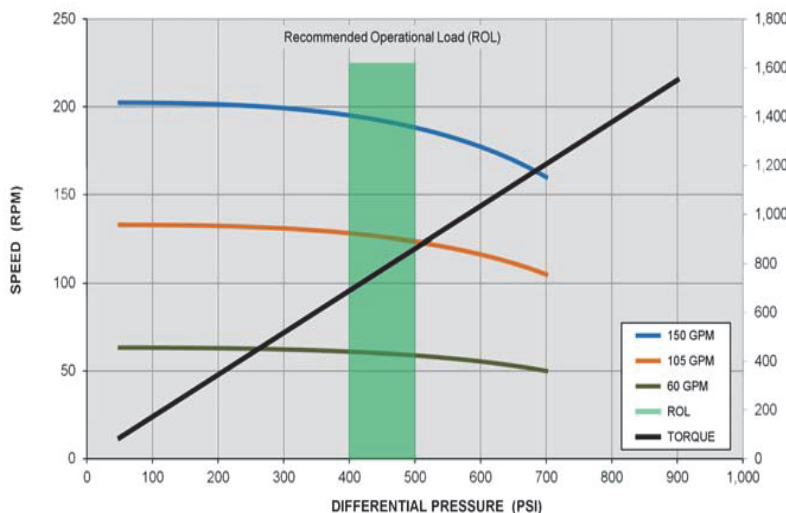

POWER CURVE

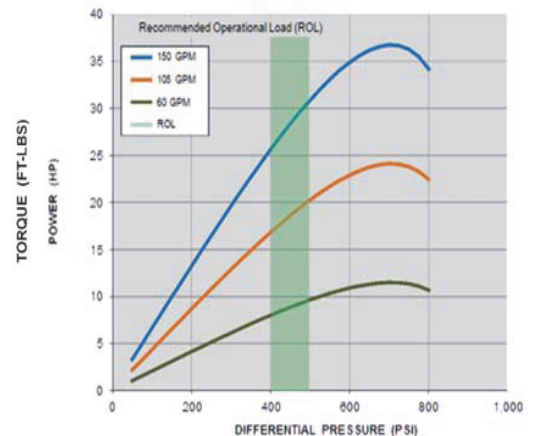

## 4-3/4" ~ 3-3/4" Sonde Mud Motor

### 9/10 Lobe 4 Stage

Motor Specifications	English	Metric
Model Number	475~375-910-4	
Motor Size	4.75 in ~ 3.75 in	120.65 mm ~ 99.25 mm
Rotor / Stator Lobes	9 / 10	
Stages	4	
Length	19 ft	5.8 m
Weight	750 lb	340.1 kg
Operating Flow Rate	60-140 GPM	227-530 LPM
Maximum Developed Power	33 hp	25 kW
Maximum Developed Torque	1,550 ft-lb	2,100 N-m
Speed @ No Load	78-183 RPM	
Revs Per Volume @ No Load	1.31 Rev/Gal	0.34 Rev/L
Differential Pressure @ No Load	200 psi	1378.9 kpa
Speed @ Full Load	50-150 RPM	
Revs Per Volume @ Full Load	1.07 Rev/Gal	0.28 Rev/L
Differential Pressure @ Full Load	600 psi	4,136.8 kpa
Bit to Bend	77.25 in	1962.15 mm
Maximum Pressure Drop	1,500 psi	10,342 kpa
Maximum Weight on Bit	12,000 lb	53 kN
Maximum Pull to Re-Run Motor	70,000 lb	266 kN
Pull to Yield Motor	200,000 lb	890 kN
Bit Box Connection	3-1/2 Reg	
Upper Box Connection	2-7/8 Reg	

Build Rate (Degrees Per 100 Feet)				
ABH Angle	Hole Size			
	4 3/4"	5"	5 1/2"	5 7/8"
0.35				
0.69	4.35	2.47		
1.04	9.08	7.20	3.50	0.78
1.37	13.54	11.65	7.94	5.22
1.69	17.87	15.97	12.25	9.52
2.00	22.06	20.16	16.42	13.68
2.29	25.98	24.07	20.33	17.58
2.57	29.86	27.87	24.10	21.34
2.83	33.28	31.36	27.60	24.83
3.06	36.39	34.47	30.69	27.93
3.28	39.36	37.44	33.66	30.88
3.46	41.80	39.87	36.08	33.30
3.63	44.09	42.16	38.37	35.59
3.76	45.85	43.92	40.12	37.33
3.86	47.20	45.27	41.47	38.68
3.94	48.29	46.35	42.55	39.75
3.98	48.83	46.89	43.08	40.29
4.00	49.10	47.16	43.35	40.56

Flow Rate	* Rev/Gal
60 GPM	0.83
105 GPM	1.00
150 GPM	1.07

\* At Full Operating Load

**PERFORMANCE CURVE**

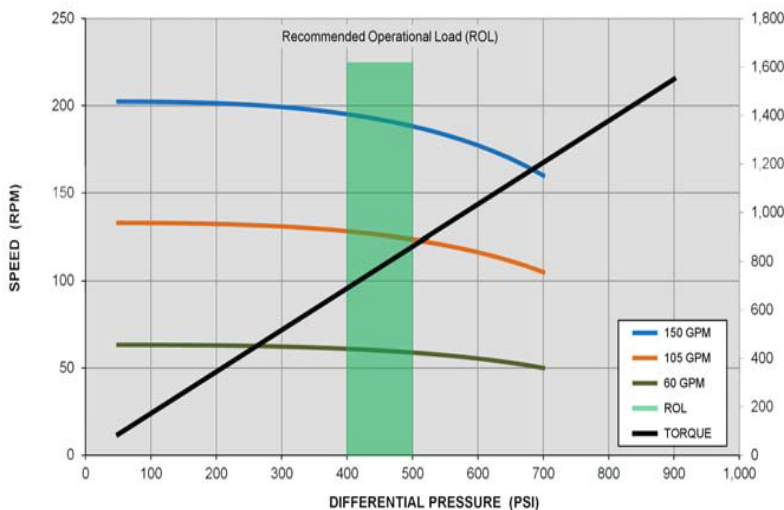

**POWER CURVE**

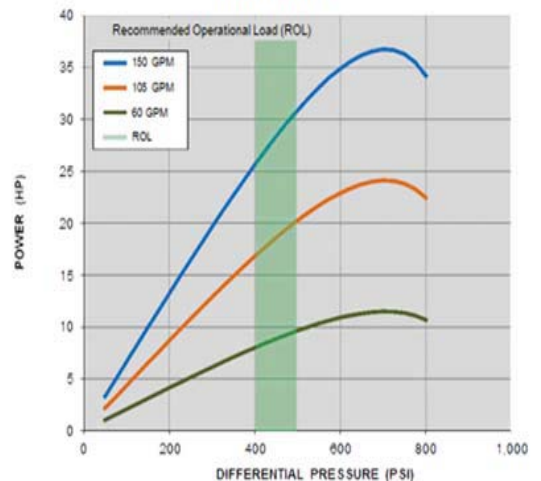

# 4-3/4" Mud Motor 9/10 Lobe 2 Stage

Motor Specifications	English	Metric
Model Number	475-910-2	
Motor Size	4.75 in	120.65 mm
Rotor / Stator Lobes	9 / 10	
Stages	2	
Length	13.4 ft	4.08 m
Weight	550 lb	249.47 kg
Operating Flow Rate	100-300 GPM	379-1,136 LPM
Maximum Developed Power	79.3 hp	59.1 kW
Maximum Developed Torque	2,900 ft-lb	3,932 N-m
Speed @ No Load	78-234 RPM	
Revs Per Volume @ No Load	0.78 Reg/Gal	0.21 Rev/L
Differential Pressure @ No Load	100 psi	689.4 kpa
Speed @ Full Load	70-210 RPM	
Revs Per Volume @ Full Load	0.70 Rev/Gal	0.18 Rev/L
Differential Pressure @ Full Load	500 psi	3,447.3 kpa
Bit to Bend	44 in	1,117.6 mm
Maximum Pressure Drop	1,500 psi	10,342 kpa
Maximum Weight on Bit	25,000 lb	11,339.8 kg
Maximum Pull to Re-Run Motor	100,000 lb	45,359.2 kg
Pull to Yield Motor	300,000 lb	136,077.7 kg
Bit Box Connection	3-1/2 Reg	
Upper Box Connection	3-1/2 Reg or 3-1/2 IF	

Build Rate (Degrees Per 100 Feet)				
ABH Angle	Hole Size			
	6"	6 1/8"	6 3/4"	7 7/8"
0.31				
0.62	1.53	0.67		
0.93	5.48	4.62	0.38	
1.22	9.18	8.31	4.06	
1.50	12.74	11.87	7.61	0.26
1.76	16.06	15.19	10.91	3.54
2.00	19.11	18.24	13.96	6.57
2.23	22.04	21.17	16.88	9.47
2.42	24.47	23.59	19.29	11.87
2.60	26.76	25.88	21.58	14.14
2.74	28.54	27.67	23.35	15.91
2.85	29.95	29.07	24.75	17.30
2.93	30.97	30.09	25.77	18.31
2.98	31.60	30.72	26.40	18.94
3.00	31.86	30.98	26.65	19.19

Flow Rate	* Rev/Gal
100 GPM	0.59
200 GPM	0.66
300 GPM	0.70

\* At Full Operating Load

PERFORMANCE CURVE

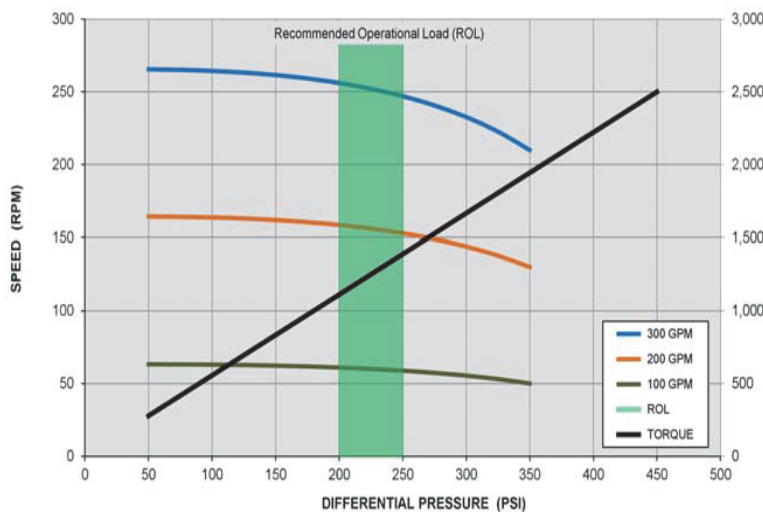

POWER CURVE

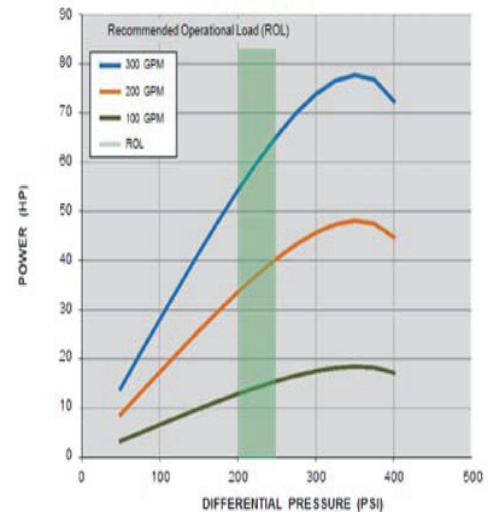

## 4-3/4" Sonde Mud Motor 9/10 Lobe 2 Stage

Motor Specifications	English	Metric
Model Number	475-910-2	
Motor Size	4.75 in	120.65 mm
Rotor / Stator Lobes	9 / 10	
Stages	2	
Length	15.4 ft	4.7 m
Weight	750 lb	340.19 kg
Operating Flow Rate	100-300 GPM	379-1,136 LPM
Maximum Developed Power	79.3 hp	59.1 kW
Maximum Developed Torque	2,900 ft-lb	3,932 N-m
Speed @ No Load	78-234 RPM	
Revs Per Volume @ No Load	0.78 Reg/Gal	0.21 Rev/L
Differential Pressure @ No Load	100 psi	689.4 kpa
Speed @ Full Load	70-210 RPM	
Revs Per Volume @ Full Load	0.70 Rev/Gal	0.18 Rev/L
Differential Pressure @ Full Load	500 psi	3,447.3 kpa
Bit to Bend	44 in	1,117.6 mm
Maximum Pressure Drop	1,500 psi	10,342 kpa
Maximum Weight on Bit	25,000 lb	11,339.8 kg
Maximum Pull to Re-Run Motor	100,000 lb	45,359.2 kg
Pull to Yield Motor	300,000 lb	136,077.7 kg
Bit Box Connection	3-1/2 Reg	
Upper Box Connection	3-1/2 Reg or 3-1/2 IF	

Build Rate (Degrees Per 100 Feet)				
ABH Angle	Hole Size			
	6"	6 1/8"	6 3/4"	7 7/8"
0.31				
0.62	1.53	0.67		
0.93	5.48	4.62	0.38	
1.22	9.18	8.31	4.06	
1.50	12.74	11.87	7.61	0.26
1.76	16.06	15.19	10.91	3.54
2.00	19.11	18.24	13.96	6.57
2.23	22.04	21.17	16.88	9.47
2.42	24.47	23.59	19.29	11.87
2.60	26.76	25.88	21.58	14.14
2.74	28.54	27.67	23.35	15.91
2.85	29.95	29.07	24.75	17.30
2.93	30.97	30.09	25.77	18.31
2.98	31.60	30.72	26.40	18.94
3.00	31.86	30.98	26.65	19.19

Flow Rate	* Rev/Gal
100 GPM	0.59
200 GPM	0.66
300 GPM	0.70

\* At Full Operating Load

PERFORMANCE CURVE

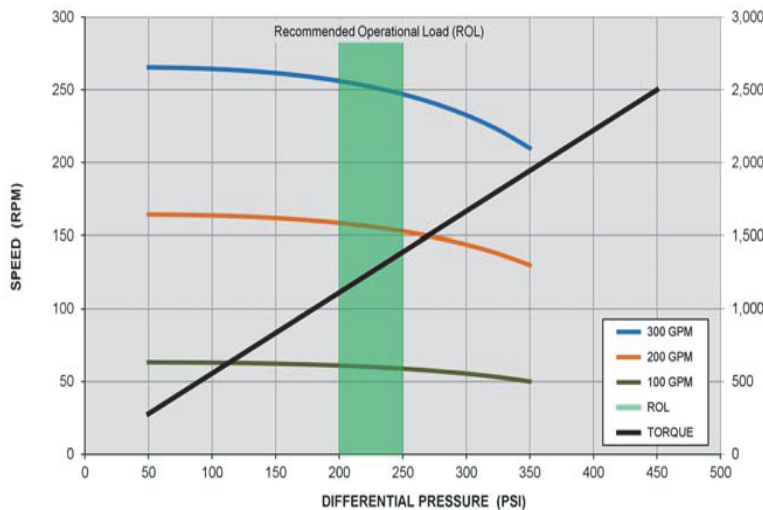

POWER CURVE

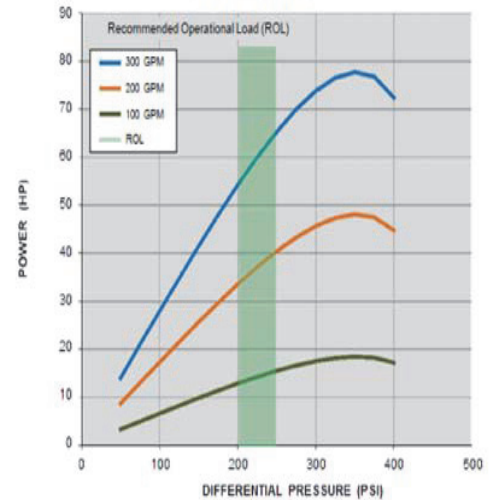



# 6-3/4" Mud Motor

## 9/10 Lobe 2.1 Stage

Motor Specifications	English	Metric
Model Number	675-910-2.1	
Motor Size	6.75 in	171.45 mm
Rotor / Stator Lobes	9 / 10	
Stages	2.1	
Length	16 ft	4.8 m
Weight	1420 lb	644.1 kg
Operating Flow Rate	250-500 GPM	946-1893 LPM
Maximum Developed Power	178.6 hp	131.36 kW
Maximum Developed Torque	5520 ft-lb	7500 N-m
Speed @ No Load	85-170 RPM	
Revs Per Volume @ No Load	0.34 Rev/G	0.089 Rev/L
Differential Pressure @ No Load	90 psi	620.5 kpa
Speed @ Full Load	65-150 RPM	
Revs Per Volume @ Full Load	0.30 Rev/Gal	0.079 Rev/L
Differential Pressure @ Full Load	780 psi	5400 kpa
Bit to Bend	60.5 in	1536.7 mm
Maximum Pressure Drop	1,500 psi	10342 kpa
Maximum Weight on Bit	75,000 lb	34,019 kg
Maximum Pull to Re-Run Motor	225,000 lb	102,058 kg
Pull to Yield Motor	650,000 lb	294,835 kg
Bit Box Connection	4-1/2 Reg	
Upper Box Connection	4-1/2 Reg or 4-1/2 IF	

Build Rate (Degrees Per 100 Feet)				
ABH Angle	Hole Size			
	8 1/2"	8 3/4"	9 7/8"	10 5/8"
0.31				
0.62	2.68	1.74		
0.93	6.19	5.24	1.07	
1.22	9.47	8.52	4.33	1.81
1.50	12.64	11.68	7.48	4.96
1.76	15.58	14.62	10.40	7.88
2.00	18.29	17.33	13.10	10.58
2.23	20.89	19.93	15.68	13.16
2.42	23.04	22.08	17.82	15.30
2.60	25.08	24.11	19.84	17.32
2.74	26.66	25.69	21.42	18.91
2.85	27.97	26.94	22.66	20.14
2.93	28.81	27.84	23.56	21.04
2.98	29.38	28.41	24.12	21.60
3.00	29.61	28.63	24.34	21.82

Flow Rate	* Rev/Gal
250 GPM	0.26
375 GPM	0.29
500 GPM	0.30

\* At Full Operating Load

PERFORMANCE CURVE

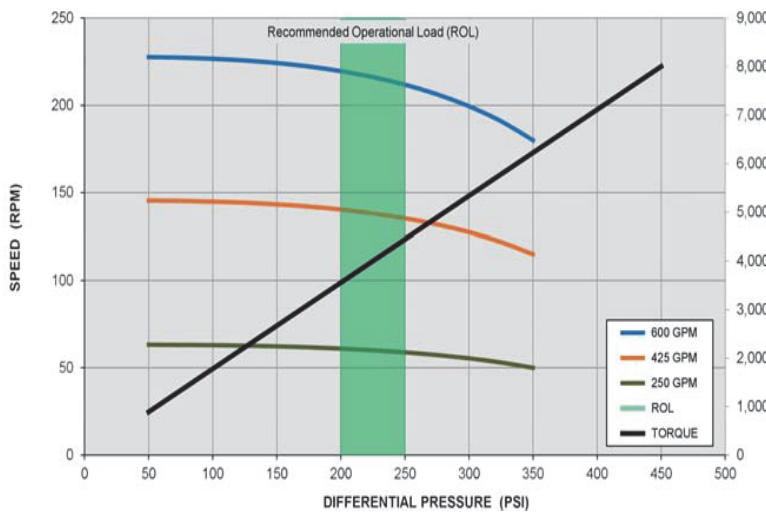

POWER CURVE

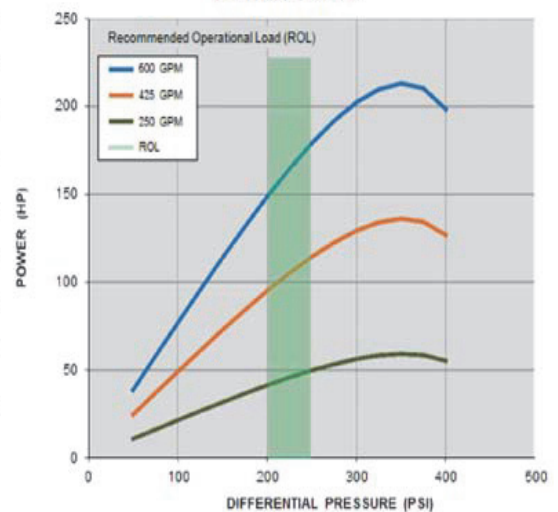

## 6-3/4" Sonde Mud Motor

### 9/10 Lobe 2.1 Stage

Motor Specifications	English	Metric
Model Number	675-910-2.1	
Motor Size	6.75 in	171.45 mm
Rotor / Stator Lobes	9 / 10	
Stages	2.1	
Length	17 ft	5.18 m
Weight	1570 lb	712.14 kg
Operating Flow Rate	250-500 GPM	946-1893 LPM
Maximum Developed Power	178.6 hp	131.36 kW
Maximum Developed Torque	5520 ft-lb	7500 N-m
Speed @ No Load	85-170 RPM	
Revs Per Volume @ No Load	0.34 Rev/G	0.089 Rev/L
Differential Pressure @ No Load	90 psi	620.5 kpa
Speed @ Full Load	65-150 RPM	
Revs Per Volume @ Full Load	0.30 Rev/Gal	0.079 Rev/L
Differential Pressure @ Full Load	780 psi	5400 kpa
Bit to Bend	89.5 in	2273.3 mm
Maximum Pressure Drop	1,500 psi	10342 kpa
Maximum Weight on Bit	75,000 lb	34,019 kg
Maximum Pull to Re-Run Motor	225,000 lb	102,058 kg
Pull to Yield Motor	650,000 lb	294,835 kg
Bit Box Connection	4-1/2 Reg	
Upper Box Connection	4-1/2 Reg or 4-1/2 IF	

Build Rate (Degrees Per 100 Feet)				
ABH Angle	Hole Size			
	8 1/2"	8 3/4"	9 7/8"	10 5/8"
0.31				
0.62	2.68	1.74		
0.93	6.19	5.24	1.07	
1.22	9.47	8.52	4.33	1.81
1.50	12.64	11.68	7.48	4.96
1.76	15.58	14.62	10.40	7.88
2.00	18.29	17.33	13.10	10.58
2.23	20.89	19.93	15.68	13.16
2.42	23.04	22.08	17.82	15.30
2.60	25.08	24.11	19.84	17.32
2.74	26.66	25.69	21.42	18.91
2.85	27.97	26.94	22.66	20.14
2.93	28.81	27.84	23.56	21.04
2.98	29.38	28.41	24.12	21.60
3.00	29.61	28.63	24.34	21.82

Flow Rate	* Rev/Gal
250 GPM	0.26
375 GPM	0.29
500 GPM	0.30

\* At Full Operating Load

PERFORMANCE CURVE

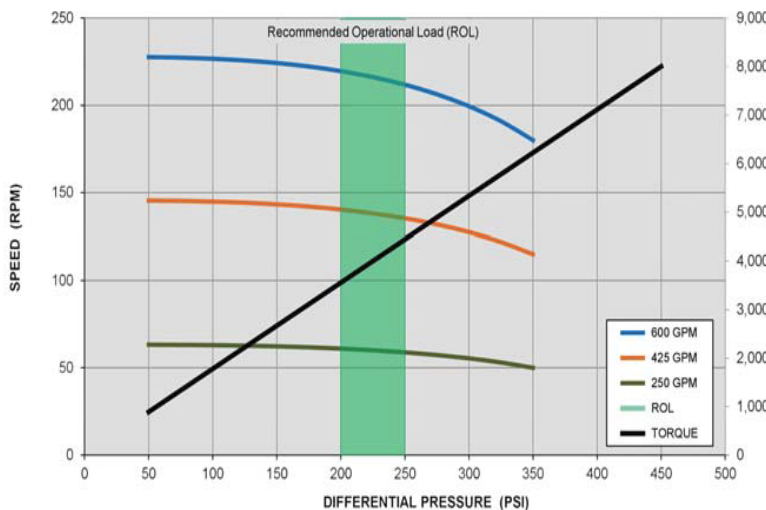

POWER CURVE

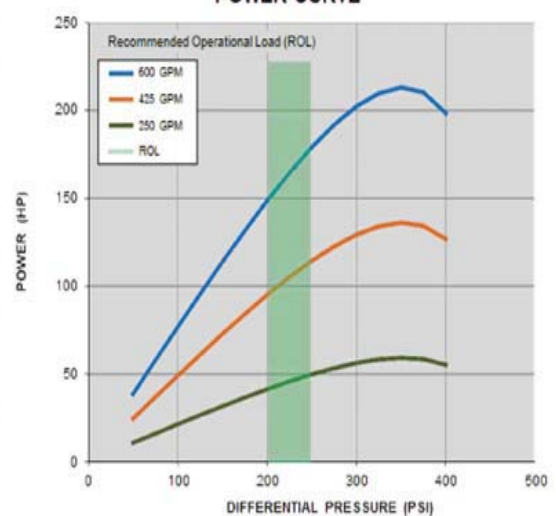

# 8" Mud Motor

## 9/10 Lobe 4 Stage

Motor Specifications	English	Metric
Model Number	8-910-4	
Motor Size	8.00 in	203.20 mm
Rotor / Stator Lobes	9 / 10	
Stages	4	
Length	24 ft	7.3 m
Weight	3020 lb	1,369.8 kg
Operating Flow Rate	300-900 GPM	1,135-3,407 LPM
Maximum Developed Power	394.6 hp	294.3 kW
Maximum Developed Torque	14,800 ft-lb	20,066.1 N-m
Speed @ No Load	84-252 RPM	
Revs Per Volume @ No Load	0.28 Rev/G	0.07 Rev/L
Differential Pressure @ No Load	50 psi	344.7 kpa
Speed @ Full Load	81-180 RPM	
Revs Per Volume @ Full Load	0.20 Rev/G	0.05 Rev/L
Differential Pressure @ Full Load	600 psi	4,140 kpa
Bit to Bend	90.5 in	27,584 mm
Maximum Pressure Drop	1,500 psi	10,342 kpa
Maximum Weight on Bit	80,000 lb	36,287 kg
Maximum Pull to Re-Run Motor	300,000 lb	136,078 kg
Pull to Yield Motor	800,000 lb	362,874 kg
Bit Box Connection	6-5/8 Reg	
Upper Box Connection	6-5/8 Reg	

Build Rate (Degrees Per 100 Feet)			
ABH Angle	Hole Size		
	9 7/8"	10 5/8"	12 1/4"
0.31			
0.62	2.06	0.12	
0.93	4.81	2.86	
1.22	7.38	5.42	1.32
1.50	9.86	7.90	3.76
1.76	12.17	10.20	6.07
2.00	14.30	12.32	8.18
2.23	16.34	14.36	10.20
2.42	18.02	16.04	11.87
2.60	19.62	17.63	13.45
2.74	20.86	18.87	14.69
2.85	21.84	19.84	15.65
2.93	22.55	20.55	16.36
2.98	22.99	20.99	16.80
3.00	23.17	21.17	16.97

Flow Rate	* Rev/Gal
300 GPM	0.27
600 GPM	0.22
900 GPM	0.20

\* At Full Operating Load

PERFORMANCE CURVE

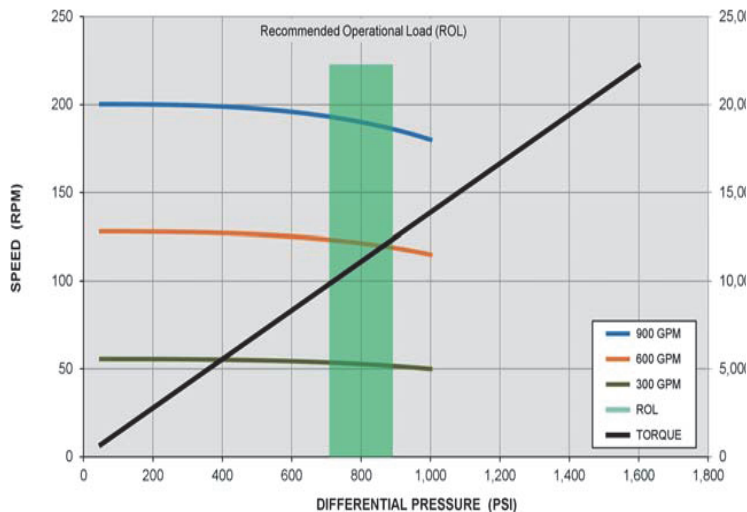

POWER CURVE

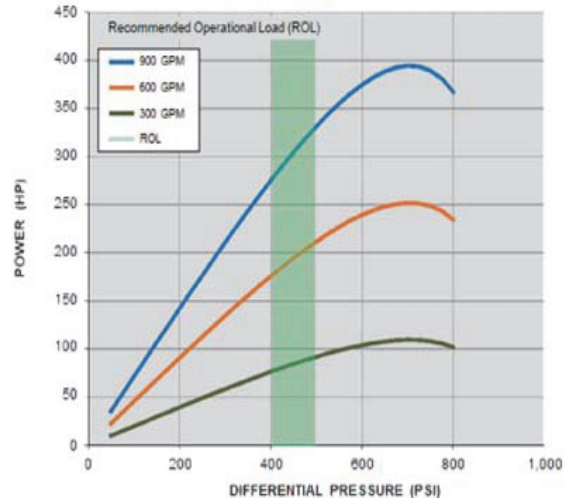



16863 Warren Ranch Road  
Hockley, Texas 77447  
U.S.A.

Phone: (713) 774-5594  
Fax: (713) 466-7552  
Toll Free: (888) 556-5511  
[www.horizontaltech.com](http://www.horizontaltech.com)  
[info@horizontaltech.com](mailto:info@horizontaltech.com)

## Motor Trouble Shooting

HTI downhole motors are designed and manufactured with strict adherence to high quality control standards. A HTI motor should provide trouble free performance when proper operational procedures are followed. However, should a problem arise, the following Trouble Shooting Charts provide commonly encountered drilling problems with their corresponding solutions.

**Note: The trouble shooting charts offer assistance in solving common motor problems that may develop. They are not intended as a substitute for experienced supervision. Should you need further assistance, please contact your nearest HTI representative.**

### Motor and Bit Off Bottom

Pump & Drill Pipe Pressure	Possible Cause	Remedy
Decrease in circulating pressure (lower than expected)	Lost circulation	Follow lost circulation procedures
	Drill string or tool washout	Pull out of hole, check string
	Leak at pressure release valve	Resolve issues at pump
Increase in circulating pressure (higher than expected)	Plugged motor or bit	Stop pumps, restart pumps, vary flow rate, trip
	Plugged Kelly lines, screens	Check Kelly lines and screens
	Bit side loading	Drill ahead carefully to relax assembly

### Drilling with Motor and Rotary

(ROP) Rate of Penetration	(DPP) Drill Pipe Pressure	(WOB) Weight on Bit	Rotary Torque	Possible Cause	Remedy
Falls	Falls	Normal	Falls	Harder formation	Optimize ROP, Continue drilling
			Rises	Bend pad catching	Cont. w/ caution or change bit
	Rises	Normal	Falls	Bit balled up	Lift off bottom, reciprocate, wash away material
				Bit worn	Change bit
			Rises	Motor stall	Cut mud, stop rotary, pull off bottom, restart
				Bearings locked	Lift off bottom, check pressure, slide forwards/backwards
	Fluctuates	Normal	Fluctuates	Trash in hole	Attempt to wash away trash
	Normal	Falls	Normal	Normal	String washed out
Rises		Normal	Normal	Plugged motor/bit	Stop pump, restart, vary pressure, reciprocate string
Rises	Rises	Normal	Rises	Softer formation	Optimize ROP, Continue drilling



16863 Warren Ranch Road  
Hockley, Texas 77447  
U.S.A.

Phone: (713) 774-5594  
Fax: (713) 466-7552  
Toll Free: (888) 556-5511  
[www.horizontaltech.com](http://www.horizontaltech.com)  
[info@horizontaltech.com](mailto:info@horizontaltech.com)

### ***Drilling with Motor Only (No Rotary)***

First Indicator	Second Indicator	Possible Cause	Remedy
No ROP	DPP higher than maximum	Motor stall	Pull off bottom, ad WOB carefully to restart
DPP higher than maximum	No ROP	Motor stall	Pull off bottom, ad WOB carefully to restart
Decrease in ROP	DPP rises, WOB normal	Broken or worn bit, bit ringing	Change bit
	DPP falls, WOB normal	Harder formation or stabilizer hanging up	Continue with caution or change bit
	DPP rises, fails to respond to increased WOB	Bit balled up	Lift off bottom, reciprocate, wash away material
	Slow fall in DPP	Bit worn	Change bit
	DPP fluctuates	BHA hitting trash in hole, cones locking up	Attempt to wash away trash
Sudden increase in ROP	DPP rises, WOB normal	Softer formation	Pull off bottom, recalculate angular reactive torque and continue drilling ahead with recalculated parameters
	Toolface heading (TFH) turns to the left	Softer formation	Pull off bottom, recalculate angular reactive torque and continue drilling ahead with recalculated parameters

***Do Not Stall Motor  
Intentionally***



16863 Warren Ranch Road  
Hockley, Texas 77447  
U.S.A.

Phone: (713) 774-5594  
Fax: (713) 466-7552  
Toll Free: (888) 556-5511  
[www.horizontaltech.com](http://www.horizontaltech.com)  
[info@horizontaltech.com](mailto:info@horizontaltech.com)

## **Steering or Build Trouble Shooting**

Be careful to match the motor's bend with the diameter of the drill bit in order to obtain adequate build capabilities. With limited right-of-way space, maintaining bend radii and finishing at the expected exit point are critical for construction. The ability to adjust the direction of the drill bit is of the utmost importance. Some tend to believe that a softer bend will benefit drilling a straighter hole. The ability to redirect and quickly adjust the drill path when the bit is drifting away from the running line will enhance the chance of a satisfactory drill path. Quicker corrections can minimize pullback and re-drills. Keeping sliding (steering) to a minimum and maximizing the footage rotating the drill string improves productivity.

### **Pre-Drill Set-Up**

The ability to accurately steer requires some standardized preparation. When jetting or using a motor, be sure all connections are properly torqued. Stalling a motor or other down-hole situations can cause connections to become loose or over torqued. This can create steering issues. Use a hammer and punch to mark the connection between the steering tool housing and motor, so that you can verify if the connection has been altered. Be sure to set a proper highside.

Steering Problem	Possible Cause	Remedy
Will not build or turn enough	Bit to bend ratio	Check build rate
	Dull bit	Slide more, replace bit
	Ledge or formation change	Allow pressure to bleed before applying more weight (Time drilling while sliding)
Over build or too much turn	Lost orientation	Trip to check connections and highside
	Formation, gravel, cobble	Rotate, slide less
Building or turns while rotating drill string	Formation, gravel, cobble	Run casing through problem are, re-drill at a different elevation, slide alternately highside up and highside down (pattern drilling)
A change in steering capabilities	Bit has become dull, formation change or ledge	Trip for bit change, adjust pattern
Will not steer/build in desired direction	Lost orientation, connection turned, lost highside	Trip and correct problem





16863 Warren Ranch Road  
Hockley, Texas 77447  
U.S.A.

Phone: (713) 774-5594  
Fax: (713) 466-7552  
Toll Free: (888) 556-5511  
[www.horizontaltech.com](http://www.horizontaltech.com)  
[info@horizontaltech.com](mailto:info@horizontaltech.com)

## Jetting Assembly

Jetting assemblies are used to provide directional capabilities through alluvial soils. They allow the user to push the drill string resulting in a direction change due to the geometry of the assembly. Jetting assemblies usually require a number of components and are customized for a rig and project. The OD and thread connections of the components should match that of the rig and, when possible, be standardized for other equipment owned by the contractor. This will minimize costs as well as down time. Horizontal Technology rents and sells complete assemblies or the individual components.

### A Standard Jetting Assembly:

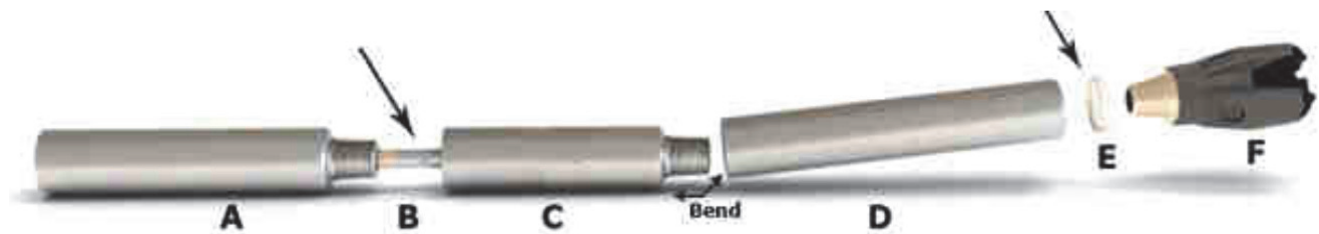

When using a magnetic steering tool, all components must be constructed from a non-magnetic material to avoid magnetic interference to the steering system. The **non-mag orientation sub (C)**, sometimes called a mule-shoe sub, houses the steering tool. A stainless steel flow through stinger slides into the rig side of the sub and is secured with set screws.

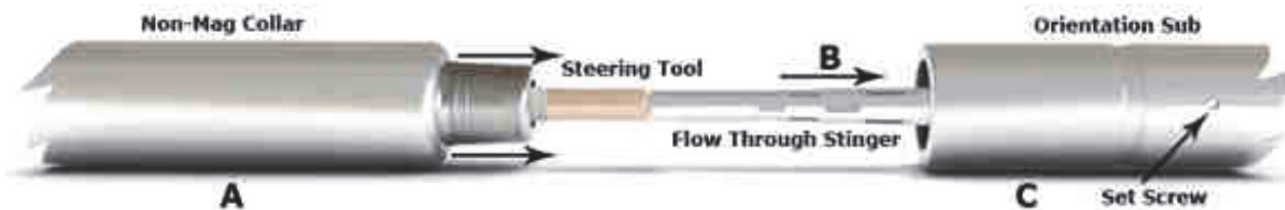

The steering tool is threaded onto the **stainless steel stinger (B)**. The stinger is ported to allow drilling fluid to pass around the steering tool and through the drill bit. The **non-mag collar or Monel (A)** slides over the steering tool and threads onto the orientation sub.

A **bent sub (D)**, also made of non-magnetic material, is threaded onto the **orientation sub (C)**. The bent sub will have a specific degree of bend. The greater the bend the more steer ability the assembly will have. This is also affected by the length of the bent sub and the diameter of the bit. A common bend for a jetting assembly 1.75 degrees. Bits are equipped with threaded pins so bent subs will have box connections on both ends.

When planning your jetting assembly, it is a good idea to have the pin connection of the orientation sub to be the same thread as the box connection on the standard drill motor that would be used for harder formations. That will allow the user to unthread the bent sub and makeup directly to the motor without reassembly of the steering tool. A variety of bits can be used on jetting assemblies. The bit size should match what is commonly used with the size drill string and rig. **Mill-tooth roller cone bits (F)** are suggested. If harder formations are encountered the bearings in the bit will relieve torque and possibly prevent an over torque situation. The ability to rotate through harder layers is enhanced with a roller cone bit versus a bladed or spade bit.

**Bit shims (E)** are used to align the jet nozzles of the bit with the bend in the bent sub. If the bit is of a single center jet style, shims are not needed. Using the shims, some users will blank two jets and align the third with the bend; others will blank one nozzle and highside the other two.



16863 Warren Ranch Road  
Hockley, Texas 77447  
U.S.A.

Phone: (713) 774-5594  
Fax: (713) 466-7552  
Toll Free: (888) 556-5511  
[www.horizontaltech.com](http://www.horizontaltech.com)  
[info@horizontaltech.com](mailto:info@horizontaltech.com)

### Bit Reference Charts

Bit Size		Milled Tooth		Tungsten Carbide Inserts		API Connection	Make-Up Torque	
in	mm	lb	kg	lb	kg		ft-lb	N-m
4 3/4	120	14	6.35	16	7.26	2 7/8 Reg	4500 - 5500	6101 - 7457
5 7/8	149	30	13.61	34	15.42	3 1/2 Reg	7000 - 9000	9491 - 12202
6 3/4	171	41	18.60	43	19.50	3 1/2 Reg	7000 - 9000	9491 - 12202
7 7/8	200	74	33.57	82	37.19	4 1/2 Reg	12000 - 16000	16270 - 21693
8 3/4	222	78	35.38	90	40.82	4 1/2 Reg	12000 - 16000	16270 - 21693
9 7/8	251	135	61.23	150	68.04	6 5/8 Reg	28000 - 32000	37963 - 43386
10 5/8	270	160	72.57	180	81.65	6 5/8 Reg	28000 - 32000	37963 - 43386
12 1/4	311	210	95.25	235	106.59	6 5/8 Reg	28000 - 32000	37963 - 43386



Reference Chart		
IADC Code	Formation	Style / Type
117	Soft	Mill-Toothed
217	Soft	Mill-Toothed
437	Soft	TCI
517	Soft to Med	TCI
527	Medium	TCI
537	Medium	TCI
547	Medium	TCI
617	Med to Hard	TCI
627	Med to Hard	TCI
637	Med to Hard	TCI
737	Hard	TCI
837	Extreme Hard	TCI

### Tungsten Carbide Insert Reference

Soft		Long extension chisel shaped carbide inserts	Aggressive design for ultra soft formations to achieve high penetration rates with minimum down pressure.
Soft		Long extension conical shaped carbide inserts	Aggressive design for ultra soft formations to achieve high penetration rates with minimum down pressure.
Medium		Short extension chisel shaped carbide inserts	Chisel shaped inserts on inner rows with gauge shape variations from chisel to dome to resist gauge rounding through the medium formation range. Extensions calculated for high penetration rates with maximum resistance to breakage.
Medium to Hard		Short extension conical shaped carbide inserts	Conical shaped inserts on inner rows with gauge variations from conical to dome for abrasive formations requiring maximum pressures. Optimum insert design for high penetration rates in formations with high compressive strengths.
Hard		Round top (dome) shaped carbide inserts	Dome shaped inserts throughout for hard to extra hard formations where heavy drilling weights are necessary. Optimum insert design and spacing for maximum resistance to abrasion and insert breakage.



16863 Warren Ranch Road  
Hockley, Texas 77447  
U.S.A.

Phone: (713) 774-5594  
Fax: (713) 466-7552  
Toll Free: (888) 556-5511  
[www.horizontaltech.com](http://www.horizontaltech.com)  
[info@horizontaltech.com](mailto:info@horizontaltech.com)

Drill Collar Connection Make-Up Torque													
Connection		Minimum Make-Up Torque (lb-ft)											
		OD (Inch)	ID (inch)										
Size	Type		1 1/4	1 1/2	1 3/4	2	2 1/4	2 1/2	2 13/16	3	3 1/4	3 1/2	3 3/4
2 3/8	Reg	3	2241	2241	1749								
		3 1/8	3028	2574	1749								
		3 1/4	3285	2574	1749								
	IF	3 1/2	4606	4606	3697								
2 7/8	Reg	3 1/2	3838	3838	3838								
		3 3/4	5766	4951	4002								
		3 7/8	5766	4951	4002								
	IF	3 7/8	4640	4640	4640	4640							
3 1/2	Reg	4 1/8	6466	6466	6466	6466	5685						
		4 1/4	7886	7886	7886	7115	5685						
		4 1/2	10471	9514	8394	7115	5685						
	IF	4 3/4			9986	9986	9986	9986	8315				
4 1/2	Reg	5 1/2			15576	15576	15576	15576	15576				
		5 3/4			20609	20609	20609	19601	16629				
		6			25407	23686	21749	19601	16629				
		6 1/4			25407	23686	21749	19601	16629				
		IF	6 1/4				23004	23004	23004	23004	23004		
		6 1/2				29679	29679	29679	29679	26675			
5 1/2	FH	7					32762	32762	32762	32762	32762		
		7 1/4					40998	40998	40998	40998	40998		
		7 1/2					49661	49661	47756	45190	41533		
		7 3/4					54515	51687	47756	45190	41533		
6 5/8	Reg	7 1/2						46399	46399	46399	46399		
		7 3/4						55627	53346	50704	46936		
		8						57393	53346	50704	46936		
		8 1/4						57393	53346	50704	46936		
	FH	8 1/2						67789	67789	67789	67789	67789	67184
		8 3/4						79544	79544	79544	76706	72102	67184
		9						88582	83992	80991	76706	72102	67184
		9 1/4						88582	83992	80991	76706	72102	67184
		9 1/2					88582	83992	80991	76706	72102	67184	
7 5/8	Reg	8 1/2						60402	60402	60402	60402	60402	60402
		8 3/4						72169	72169	72169	72169	72169	72169
		9						84442	84442	84442	84221	79536	74529
		9 1/4						96301	91663	88580	84221	79536	74529
		9 1/2						96301	91633	88580	84221	79536	74529

**HDD's Best Hole Opener Just Got Better!!!**

**STRONGER \* LONGEST LASTING \* LOWER TORQUE**

**8 3/4" to 72"**

**Better Production, Lower Costs**

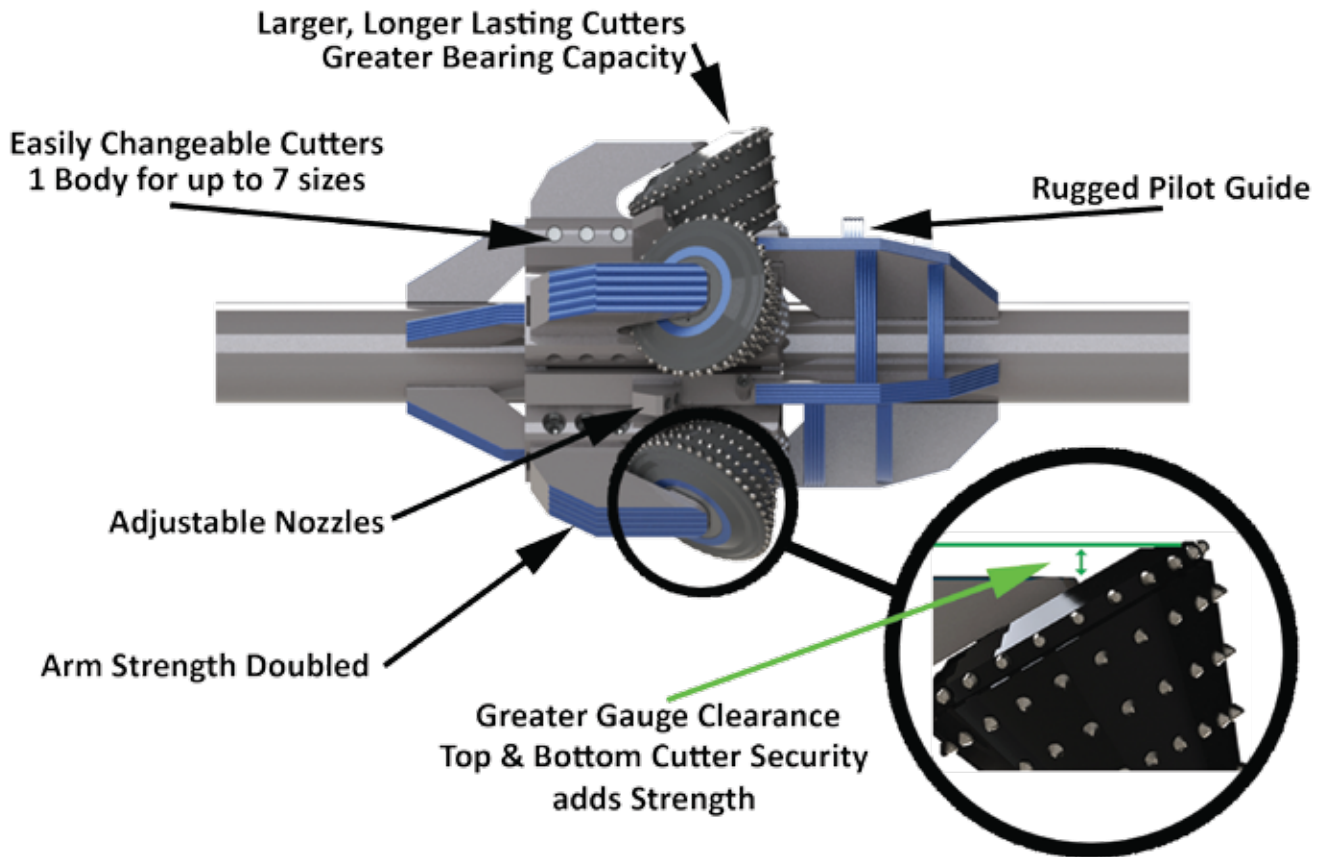

**FEATURES**

- Proprietary Bearing Design
- Larger Cutter
- Maximum Shirrtail Protection
- Engineered Insert Configuration
- Customized / Reverse Nozzles
- Match the Cutter to the Formation
- Stronger Design
- Versatile Design
- Easily Changeable Cutters



**\$ BENEFITS \$**

- Increased Weight Capability With Less Torque
- Longer Cutter Life
- Improved Cutter Security
- Maximum Cutter Efficiency
- Improved Circulation & Cleaning
- Improved Penetration Rates
- Minimizes Risk, Longer Life
- Lowers Cost
- No Down-Time